

## 150mA High Voltage Regulator

### General Description

The WR0115 series is a set of low power high voltage regulators implemented in CMOS technology which can provide 150mA output current. The device allows input voltage as high as 40V. The WR0115 series is available in several fixed output voltages.

Although designed primarily as fixed voltage regulators, the device can be used with external components to obtain variable output voltages.

The WR0115 series is available in Green SOT23-3, SOT23-5/L and SOT89-3/L packages. It operates over an ambient temperature range of -40°C to +85°C.

### Feature

- Low Power Consumption
- 150mA Nominal Output Current
- Low Dropout Voltage
- Low Temperature Coefficient
- High Input Voltage (up to 40V)
- Output Voltage Accuracy:  $\pm 3\%$
- Fixed Output Voltage Versions: 0.8V to 4.7V with 0.1V per Step 5V to 12V with 0.25V per Step
- -40°C to +85°C Operating Temperature Range
- Available in Green SOT23-3, SOT23-5/L and SOT89-3/L Packages

### Applications

- Battery-Powered Equipment
- Communication Equipment
- Audio/Video Equipment

### Typical Application

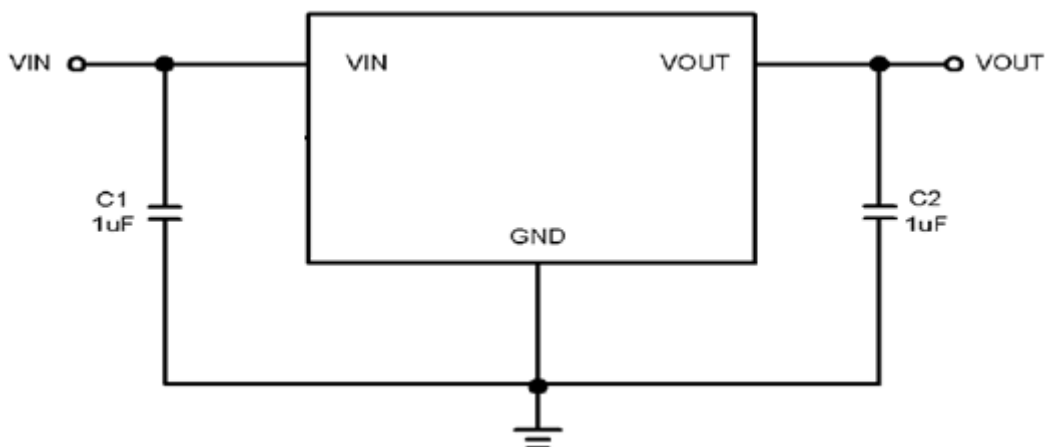

## Pin Configuration

(Top View)

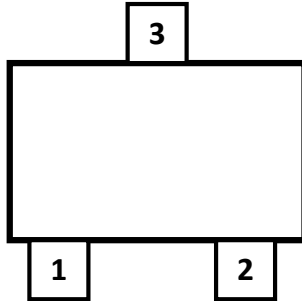

SOT23-3

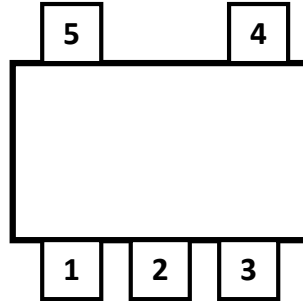

SOT23-5/L

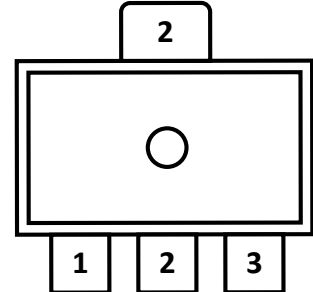

SOT89-3/L

## Pin Description

Pin Number					Pin Name	Description
SOT23-3	SOT23-5L	SOT23-5	SOT89-3	SOT89-3L		
1	1	2	2	1	GND	Ground
2	3	5	1	3	OUT	Regulator Output
3	2	1	3	2	IN	Regulator Input
-	4,5	3,4	-	-	NC	Not connect

**Absolute Maximum Ratings**

Parameter		Rating	Unit
Input voltage range		-0.3 ~ 44	V
Output voltage range		-0.3 ~ 6	V
Power Dissipation $P_D @ T_A=25^\circ\text{C}$	SOT23-3	500	mW
	SOT23-5/L	500	mW
	SOT89-3/L	625	mW
Thermal Resistance, $\theta_{JA}$	SOT23-3	250	$^\circ\text{C/W}$
	SOT23-5/L	250	$^\circ\text{C/W}$
	SOT89-3/L	200	$^\circ\text{C/W}$
Operating Junction Temperature		150	$^\circ\text{C}$
Lead Temperature Range		260	$^\circ\text{C}$
Storage Temperature Range		-65 ~ 150	$^\circ\text{C}$
ESD Susceptibility	HBM	$\pm 4000$	V

**Recommended Operating Conditions**

Parameter	Rating	Unit
Operating Supply voltage	2.7 ~ 40	V
Operating Temperature Range	-40~+85	$^\circ\text{C}$

# WR0115

## Electrical Characteristics

( $V_{IN} = V_{OUT} + 2V$  or  $4V$ , whichever is greater,  $C_{IN} = C_{OUT} = 1\mu F$ , Full =  $-40^{\circ}C$  to  $+85^{\circ}C$ , typical values are at  $T_A = +25^{\circ}C$ , unless otherwise noted.)

symbol	Parameter	Test Condition		Temp	Min	Typ	Max	Unit
$V_{IN}$	Input Voltage	$V_{OUT} < 3.3v$		Full	2.7		36	V
		$V_{OUT} \geq 3.3v$		Full	2.7		40	
$V_{OUT}$	Output Voltage	$I_{OUT} = 1mA$		$+25^{\circ}C$	0.97 $V_{OUT}$	$V_{OUT}$	1.03 $V_{OUT}$	V
$I_{OUT}$	Maximum Output Current <sup>1</sup>			$+25^{\circ}C$	150			mA
$V_{DO}$	Dropout Voltage <sup>2</sup>	$I_{OUT} = 150mA, V_{OUT} \geq 2.5v$		$+25^{\circ}C$		1100	1850	mV
				Full			2400	
LNR	Line Regulation	$V_{IN} = V_{OUT} + 2v$ or $4v$ to $32v, I_{OUT} = 1mA$	$V_{OUT} < 3.3v$	$+25^{\circ}C$		0.01		%V
		$V_{IN} = V_{OUT} + 2v$ or $4v$ to $40v, I_{OUT} = 1mA$	$V_{OUT} \geq 3.3v$	$+25^{\circ}C$		0.01		
LDR	Load Regulation <sup>3</sup>	$V_{IN} = V_{OUT} + 2v$ or $4v, I_{OUT} = 1mA$ to $150mA$		$+25^{\circ}C$		5		mV
IQ	Ground Pin Current	No load		$+25^{\circ}C$		3.5	5.5	uA
		$I_{OUT} = 1mA$		$+25^{\circ}C$		3.5		
$\frac{\Delta V_{OUT}}{\Delta T_A \times V_{OUT}}$	Output Voltage Temperature Coefficient <sup>4</sup>	$I_{OUT} = 1mA$		Full		53		ppm/ $^{\circ}C$
PSRR	Power Supply Rejection Ratio	$V_{OUT} = 3.3v, I_{OUT} = 10mA$	$f = 217Hz$	$+25^{\circ}C$		60		dB
			$f = 1kHz$	$+25^{\circ}C$		50		
$T_{SD}$	Thermal Shutdown Temperature					150		$^{\circ}C$
$\Delta T_{SD}$	Thermal Shutdown Hysteresis					20		$^{\circ}C$

Note1: Maximum output current is affected by the PCB layout, size of metal trace, the thermal conduction path between metal layers, ambient temperature and the other environment factors of system. Attention should be paid to the dropout voltage when  $V_{IN} < V_{OUT} + V_{drop}$ .

Note2: The dropout voltage is defined as  $V_{IN} - V_{OUT}$ , when  $V_{OUT}$  is 95% of the value of  $V_{OUT}$  for  $V_{IN} = V_{OUT} + 2v$ .

Note3: The Load regulation is measured using pulse technique with duty cycle  $< 5\%$ .

Note4: Output voltage temperature coefficient is defined as the worst-case voltage change divided by the total temperature range.

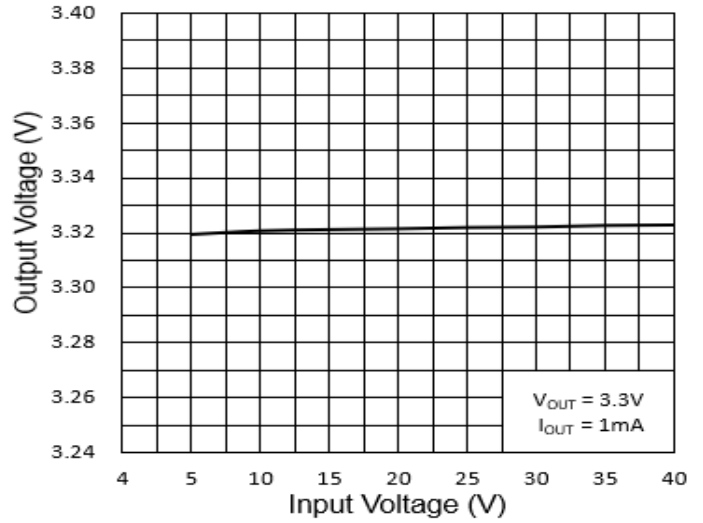
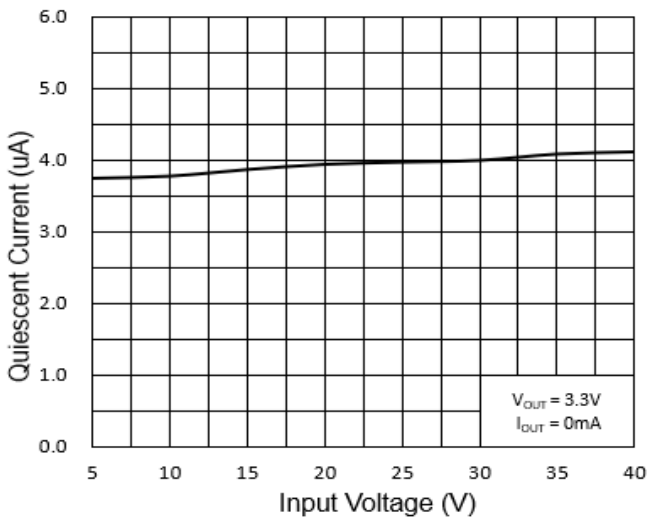
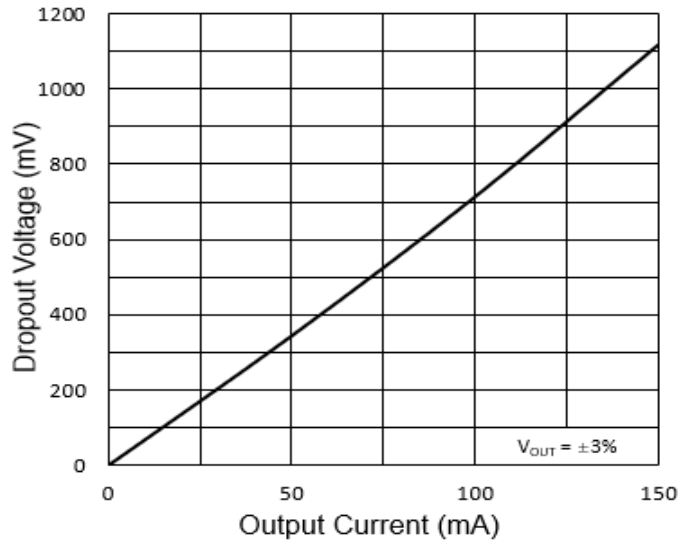
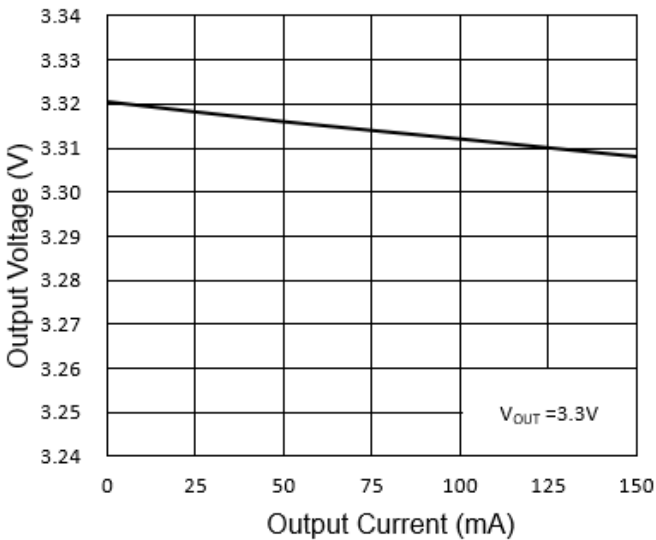
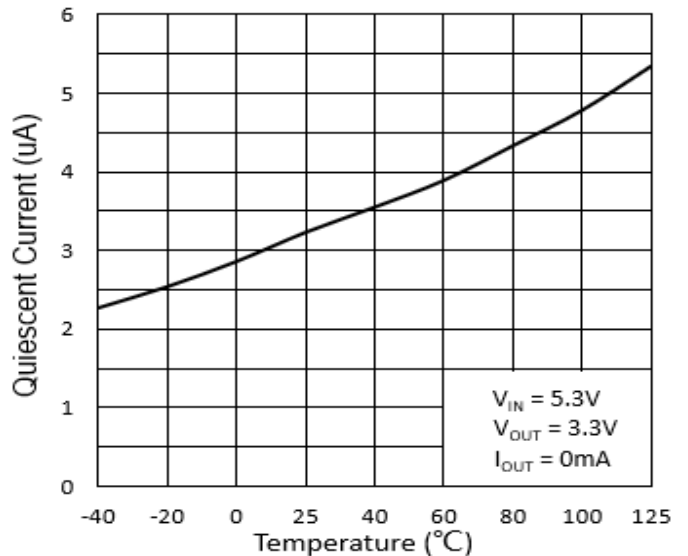
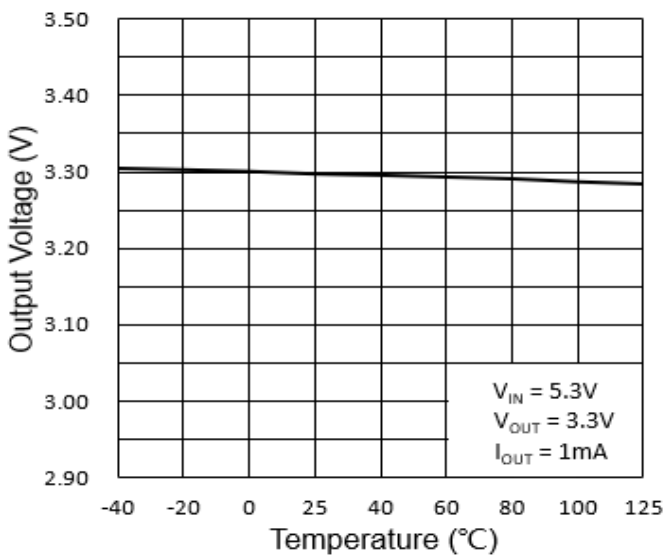
**Typical Characteristics** ( $T_a=25^\circ\text{C}$ ,  $V_{IN}=V_{OUT}+2\text{V}$ ,  $C_{IN}=C_{OUT}=1\mu\text{F}$ , unless otherwise noted)

**Quiescent Current vs. Supply Voltage**
**Output Voltage vs. Supply Voltage**

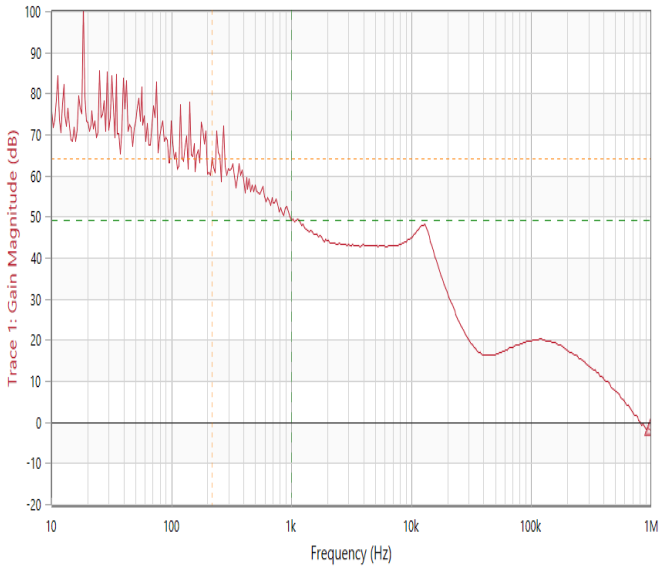
**Output Voltage vs. Output Current**
**Dropout Voltage vs. Output Current**

**Output Voltage vs. Temperature**
**Quiescent Current vs. Temperature**

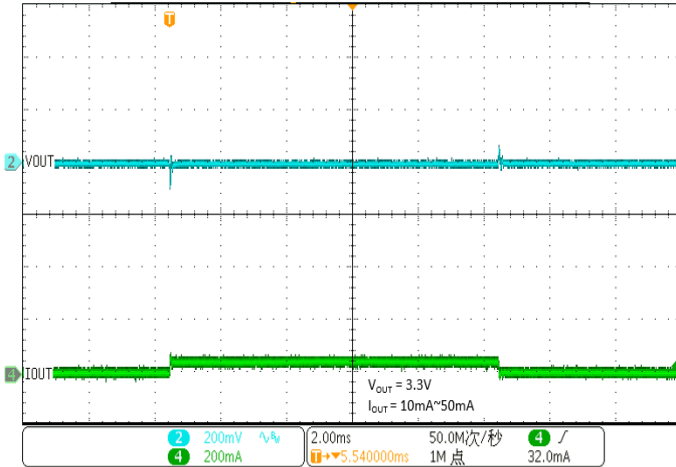
# WR0115



Power Supply Rejection Ratio vs. Frequency



Load-Transient Response

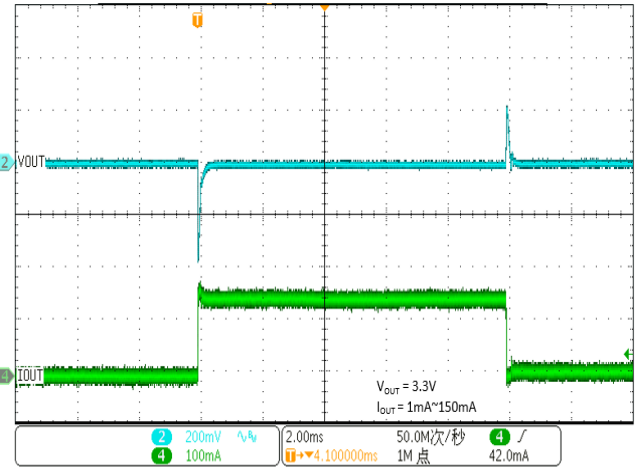

Load-Transient Response

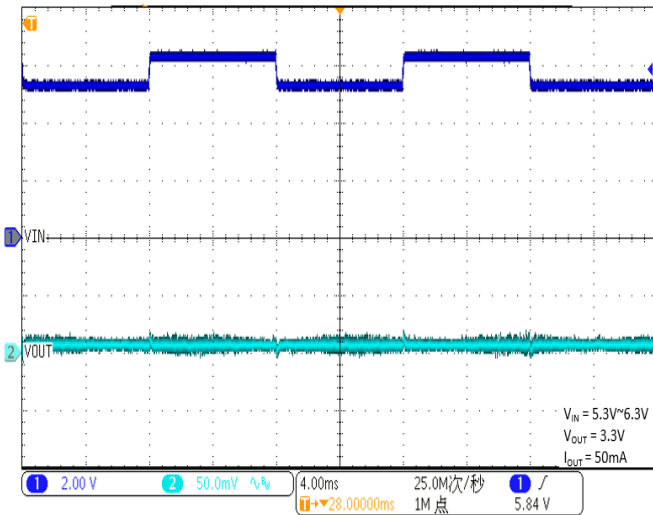

Line-Transient Response

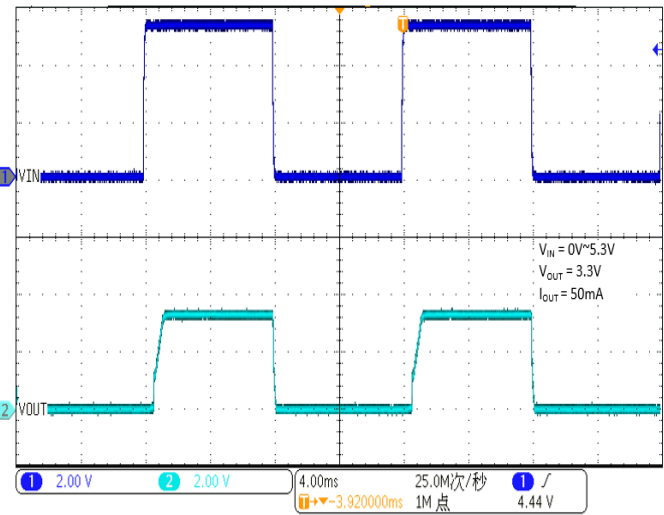

Power-Up/Power-Down Output Waveform

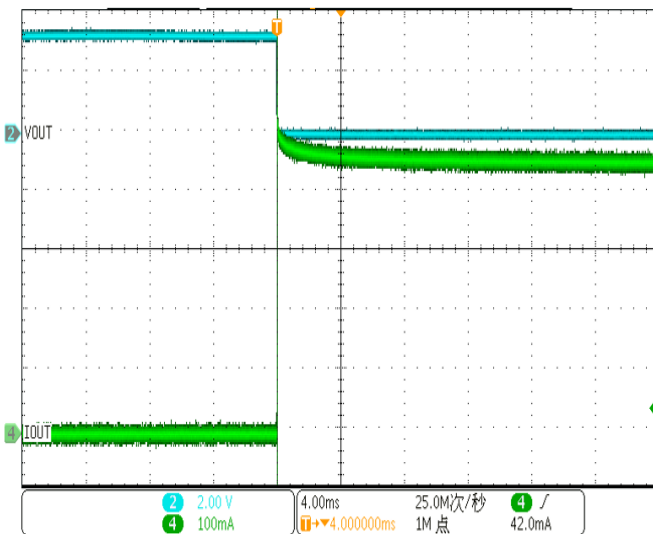

Output short Waveform

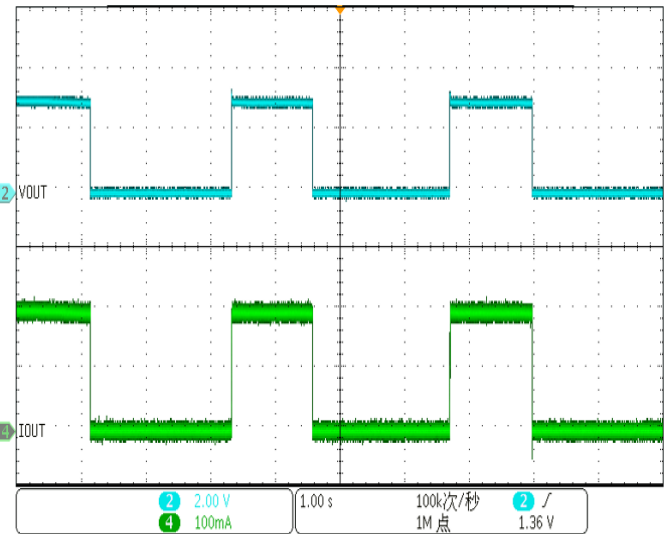

Thermal Protection Waveform

Block Diagram

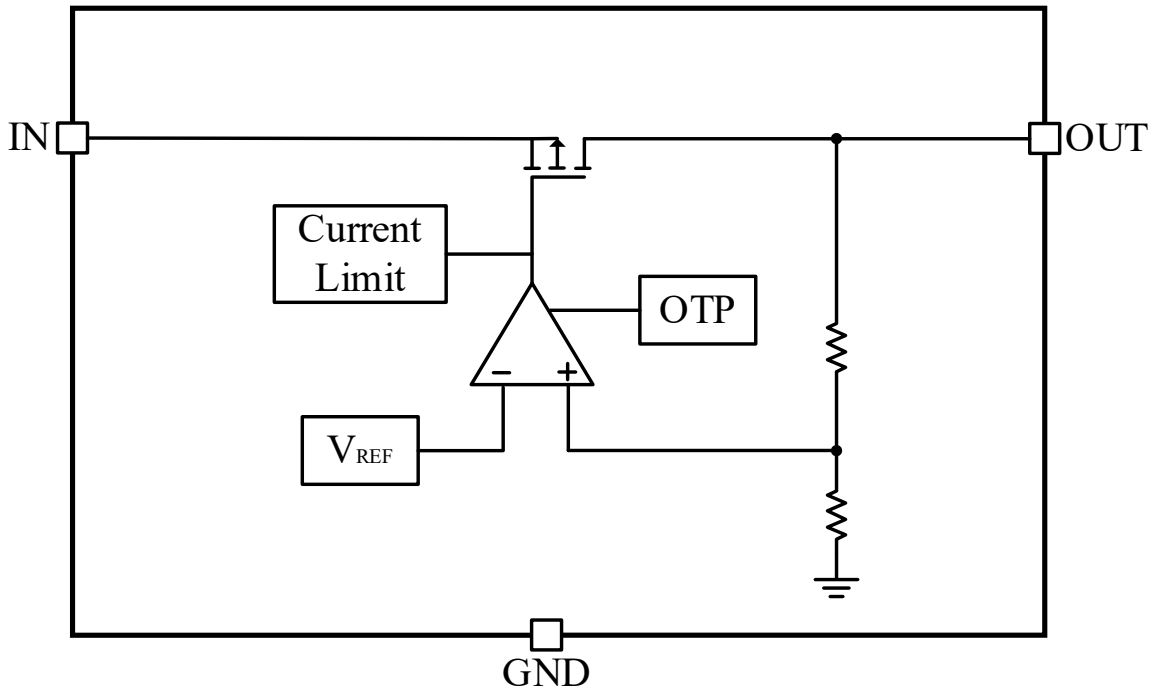

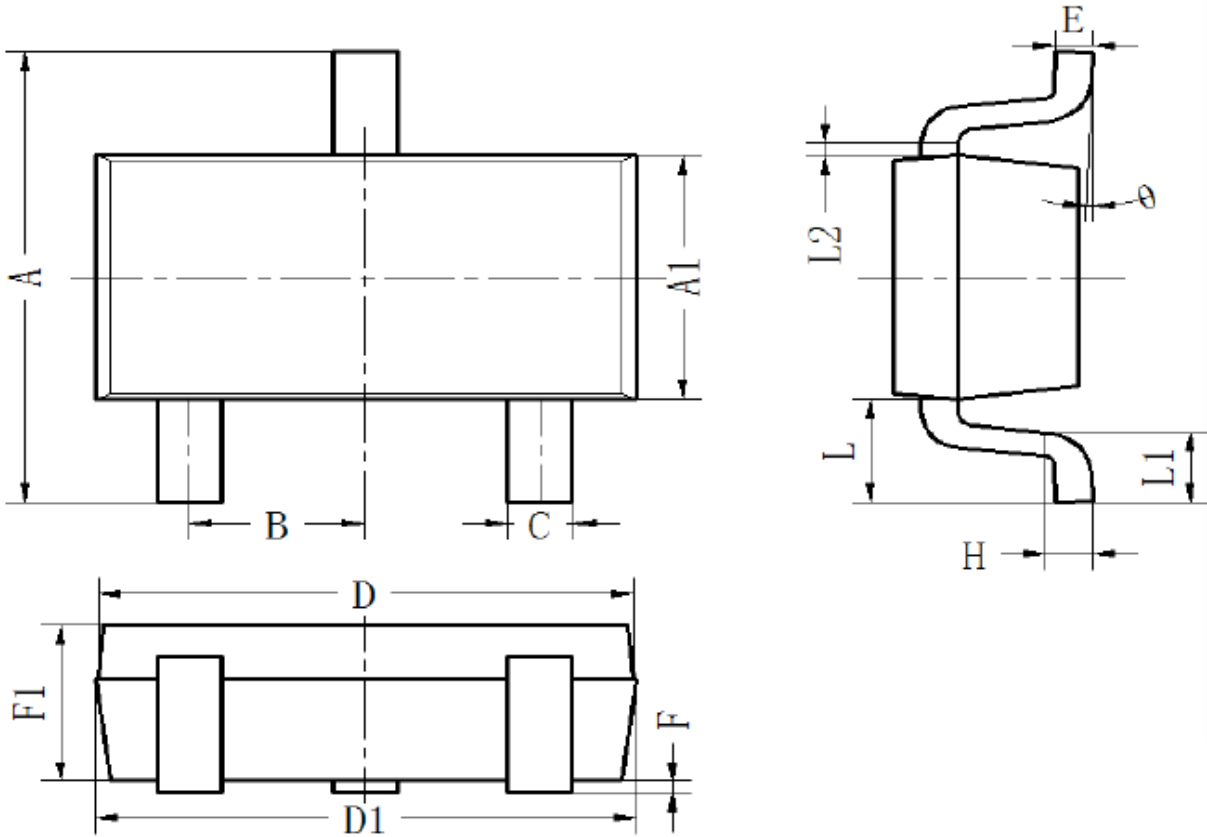

**Package Information**

**SOT 23-3L**

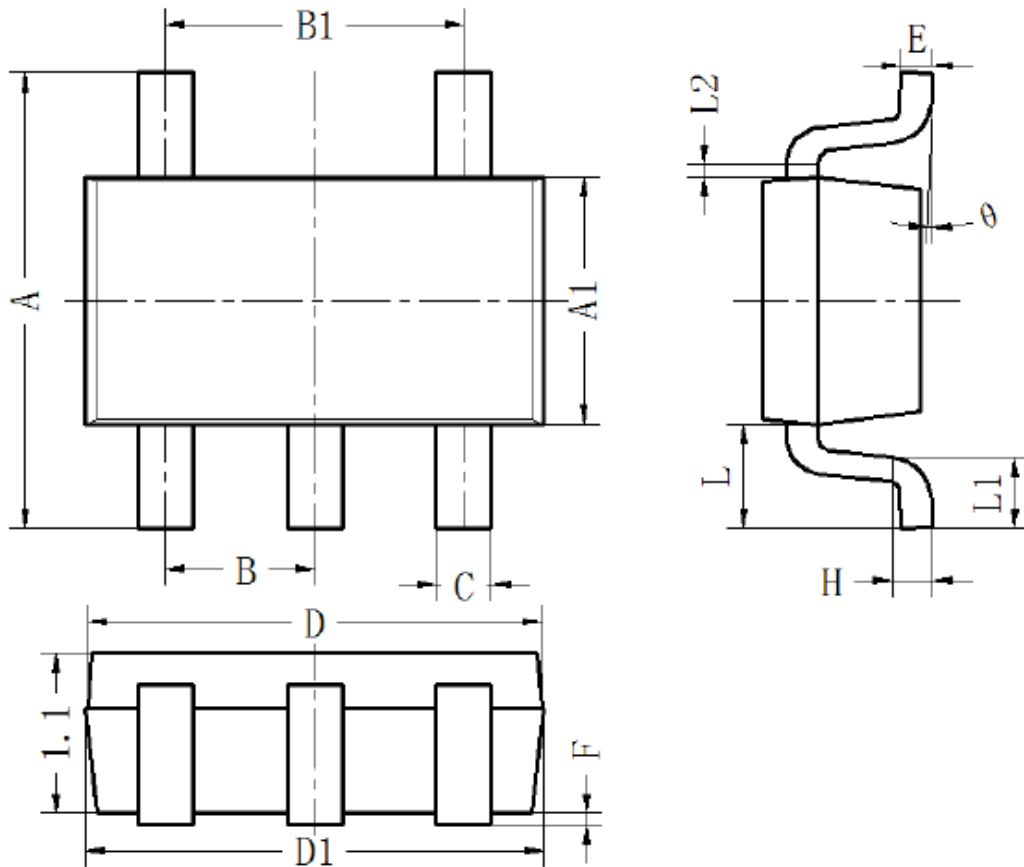
SYMBOL	DIMENSIONS IN MILLIMETERS		
	MIN	NOM	MAX
<b>A</b>	2.65	2.8	2.95
<b>A1</b>	1.5	1.6	1.7
<b>B</b>	0.90	0.95	1.00
<b>C</b>	0.3	0.4	0.5
<b>D</b>	2.82	2.92	3.02
<b>D1</b>	2.87	2.92	2.97
<b>E</b>	0.1	0.15	0.2
<b>H</b>	0.204	0.254	0.304
<b>L</b>	0.55	0.65	0.75
<b>L1</b>	0.3	0.45	0.6
<b>L2</b>	0.06	0.08	0.10
<b>F1</b>	1.05	1.1	1.15
<b>F</b>	0.02	0.08	0.15

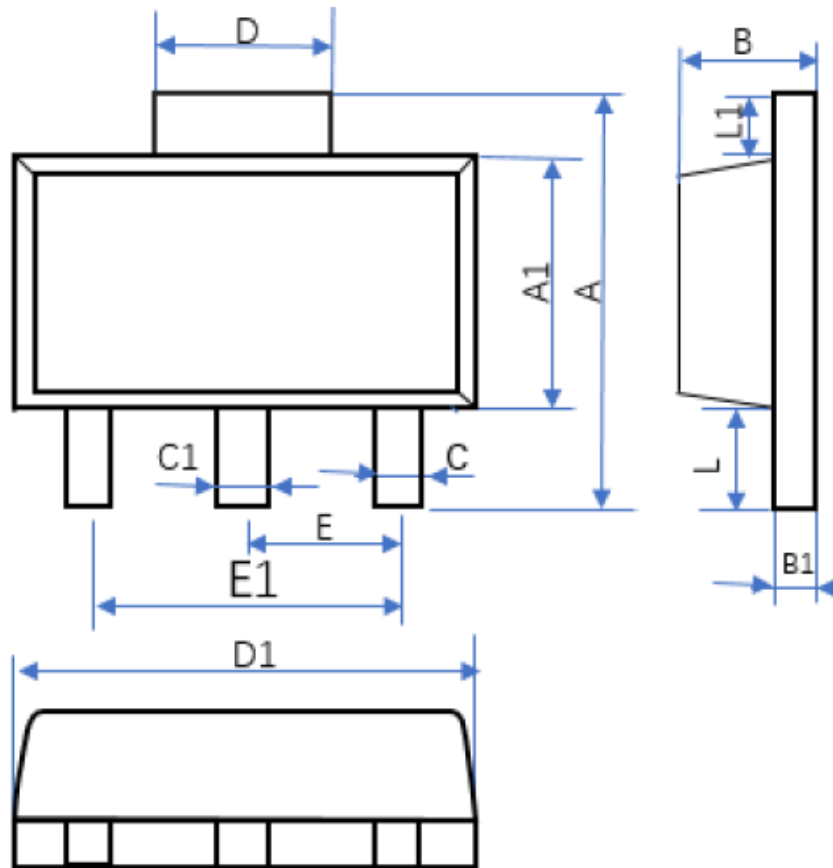

SOT 23-5/L

SYMBOL	DIMENSIONS IN MILLIMETERS		
	MIN	NOM	MAX
A	2.8	2.9	3.0
A1	1.5	1.6	1.7
B	0.90	0.95	1.0
B1	1.8	1.9	2.0
C	0.35	0.4	0.45
D	2.79	2.89	2.99
D1	2.82	2.92	3.02
E	0.1	0.15	0.2
F	0.02	0.08	0.14
H	0.254	0.254	0.254
L	0.55	0.65	0.75
L1	0.35	0.45	0.55
L2	0.08	0.08	0.08
$\theta$	2		8



**SOT89-3/L**

SYMBOL	DIMENSIONS IN MILLIMETERS		
	MIN	NOM	MAX
<b>A</b>	3.95	4.10	4.25
<b>A1</b>	2.45	2.50	2.55
<b>B</b>	1.44	1.49	1.54
<b>B1</b>	0.35	0.40	0.45
<b>C</b>	0.35	0.40	0.45
<b>C1</b>	0.45	0.50	0.55
<b>D</b>	1.65	1.70	1.75
<b>D1</b>	4.45	4.50	4.55
<b>E</b>	1.45	1.50	1.55
<b>E1</b>	2.95	3.00	3.05
<b>L</b>	0.95	1.02	1.09
<b>L1</b>	0.55	0.60	0.65

## Ordering Information

Part Number	Output Voltage	Package	Packing Quantity	Marking*
WR0115-12A30R	1.2V	SOT23-3	3k/Reel	WR0115 12 XXXX
WR0115-15A30R	1.5V	SOT23-3	3k/Reel	WR0115 15 XXXX
WR0115-18A30R	1.8V	SOT23-3	3k/Reel	WR0115 18 XXXX
WR0115-20A30R	2.0V	SOT23-3	3k/Reel	WR0115 20 XXXX
WR0115-22A30R	2.2V	SOT23-3	3k/Reel	WR0115 22 XXXX
WR0115-25A30R	2.5V	SOT23-3	3K/Reel	WR0115 25 XXXX
WR0115-28A30R	2.8V	SOT23-3	3k/Reel	WR0115 28 XXXX
WR0115-30A30R	3.0V	SOT23-3	3k/Reel	WR0115 30 XXXX
WR0115-33A30R	3.3V	SOT23-3	3k/Reel	WR0115 33 XXXX
WR0115-36A30R	3.6V	SOT23-3	3k/Reel	WR0115 36 XXXX
WR0115-45A30R	4.5V	SOT23-3	3k/Reel	WR0115 45 XXXX
WR0115-50A30R	5.0V	SOT23-3	3k/Reel	WR0115 50 XXXX
WR0115-A2A30R	12V	SOT23-3	3k/Reel	WR0115 A2 XXXX
WR0115-12A50R	1.2V	SOT23-5	3k/Reel	WR0115 12 XXXX
WR0115-15A50R	1.5V	SOT23-5	3k/Reel	WR0115 15 XXXX
WR0115-18A50R	1.8V	SOT23-5	3k/Reel	WR0115 18 XXXX
WR0115-20A50R	2.0V	SOT23-5	3k/Reel	WR0115 20 XXXX
WR0115-22A50R	2.2V	SOT23-5	3k/Reel	WR0115 22 XXXX
WR0115-25A50R	2.5V	SOT23-5	3k/Reel	WR0115 25 XXXX
WR0115-28A50R	2.8V	SOT23-5	3k/Reel	WR0115 28 XXXX
WR0115-30A50R	3.0V	SOT23-5	3k/Reel	WR0115 30 XXXX
WR0115-33A50R	3.3V	SOT23-5	3k/Reel	WR0115 33 XXXX
WR0115-36A50R	3.6V	SOT23-5	3k/Reel	WR0115 36 XXXX
WR0115-45A50R	4.5V	SOT23-5	3k/Reel	WR0115 45 XXXX
WR0115-50A50R	5.0V	SOT23-5	3k/Reel	WR0115 50 XXXX
WR0115-A2A50R	12V	SOT23-5	3k/Reel	WR0115 A2 XXXX
WR0115-12A51R	1.2V	SOT23-5L	3k/Reel	WR0115 12 XXXX
WR0115-15A51R	1.5V	SOT23-5L	3k/Reel	WR0115 15 XXXX
WR0115-18A51R	1.8V	SOT23-5L	3k/Reel	WR0115 18 XXXX
WR0115-20A51R	2.0V	SOT23-5L	3k/Reel	WR0115 20 XXXX
WR0115-22A51R	2.2V	SOT23-5L	3k/Reel	WR0115 22 XXXX
WR0115-25A51R	2.5V	SOT23-5L	3k/Reel	WR0115 25 XXXX
WR0115-28A51R	2.8V	SOT23-5L	3k/Reel	WR0115 28 XXXX
WR0115-30A51R	3.0V	SOT23-5L	3k/Reel	WR0115 30 XXXX

Part Number	Output Voltage	Package	Packing Quantity	Marking*
WR0115-33A51R	3.3V	SOT23-5L	3k/Reel	WR0115 33 XXXX
WR0115-36A51R	3.6V	SOT23-5L	3k/Reel	WR0115 36 XXXX
WR0115-45A51R	4.5V	SOT23-5L	3k/Reel	WR0115 45 XXXX
WR0115-50A51R	5.0V	SOT23-5L	3k/Reel	WR0115 50 XXXX
WR0115-A2A51R	12V	SOT23-5L	3k/Reel	WR0115 A2 XXXX
WR0115-12A20R	1.2V	SOT89-3	1k/Reel	WR0115 12 XXXX
WR0115-15A20R	1.5V	SOT89-3	1k/Reel	WR0115 15 XXXX
WR0115-18A20R	1.8V	SOT89-3	1k/Reel	WR0115 18 XXXX
WR0115-20A20R	2.0V	SOT89-3	1k/Reel	WR0115 20 XXXX
WR0115-22A20R	2.2V	SOT89-3	1k/Reel	WR0115 22 XXXX
WR0115-25A20R	2.5V	SOT89-3	1k/Reel	WR0115 25 XXXX
WR0115-28A20R	2.8V	SOT89-3	1k/Reel	WR0115 28 XXXX
WR0115-30A20R	3.0V	SOT89-3	1k/Reel	WR0115 30 XXXX
WR0115-33A20R	3.3V	SOT89-3	1k/Reel	WR0115 33 XXXX
WR0115-36A20R	3.6V	SOT89-3	1k/Reel	WR0115 36 XXXX
WR0115-45A20R	4.5V	SOT89-3	1k/Reel	WR0115 45 XXXX
WR0115-50A20R	5.0V	SOT89-3	1k/Reel	WR0115 50 XXXX
WR0115-A2A20R	12V	SOT89-3	1k/Reel	WR0115 A2 XXXX
WR0115-12A21R	1.2V	SOT89-3L	1k/Reel	WR0115 12 XXXX
WR0115-15A21R	1.5V	SOT89-3L	1k/Reel	WR0115 15 XXXX
WR0115-18A21R	1.8V	SOT89-3L	1k/Reel	WR0115 18 XXXX
WR0115-20A21R	2.0V	SOT89-3L	1k/Reel	WR0115 20 XXXX
WR0115-22A21R	2.2V	SOT89-3L	1k/Reel	WR0115 22 XXXX
WR0115-25A21R	2.5V	SOT89-3L	1k/Reel	WR0115 25 XXXX
WR0115-28A21R	2.8V	SOT89-3L	1k/Reel	WR0115 28 XXXX
WR0115-30A21R	3.0V	SOT89-3L	1k/Reel	WR0115 30 XXXX
WR0115-33A21R	3.3V	SOT89-3L	1k/Reel	WR0115 33 XXXX
WR0115-36A21R	3.6V	SOT89-3L	1k/Reel	WR0115 36 XXXX
WR0115-45A21R	4.5V	SOT89-3L	1k/Reel	WR0115 45 XXXX
WR0115-50A21R	5.0V	SOT89-3L	1k/Reel	WR0115 50 XXXX
WR0115-A2A21R	12V	SOT89-3L	1k/Reel	WR0115 A2 XXXX

\*XXXX is variable.

## Contact Information

No.1001, Shiwan(7) Road, Pudong District, Shanghai, P.R.China.201202

Tel: 86-21-68960674 Fax: 86-21-50757680 Email: [market@way-on.com](mailto:market@way-on.com)

WAYON website: <http://www.way-on.com>

For additional information, please contact your local Sales Representative.

 is registered trademark of Wayon Corporation.

*Specifications are subject to change without notice.*

*The device characteristics and parameters in this data sheet can and do vary in different applications and actual device performance may vary over time*

*Users should verify actual device performance in their specific applications.*