

Ultra-Low I_Q 150mA CMOS LDO Regulator

General Description

The WR0114 series of CMOS low dropout regulators are designed specifically for portable battery-powered applications which require ultra-low quiescent current. The ultra-low consumption of typ 800nA ensures long battery life and dynamic transient boost feature improves device transient response for wireless communication applications.

The device is available in SOT23-3, SOT23-5 and DFN1x1-4 packages.

Features

- Operating Input Voltage Range: 2.2 V to 5.5 V
- Output Voltage Range: 1.2 V to 3.3 V (0.1 V Steps)
- Ultra-Low Quiescent Current Typ 0.8μA
- Low Dropout: 170 mV Typ at 150mA @V_{OUT}=3.0V
- High Output Voltage Accuracy ±1%
- Stable with Ceramic Capacitors 1μF
- Over-Current Protection
- Thermal Shutdown Protection
- Active Discharge Feature
- These Devices are Pb-Free, Halogen Free/BFR Free and are RoHS Compliant

Applications

- Cameras, Image Sensors and Camcorders
- Portable Communication Equipment
- Battery Powered Equipment

Typical Application

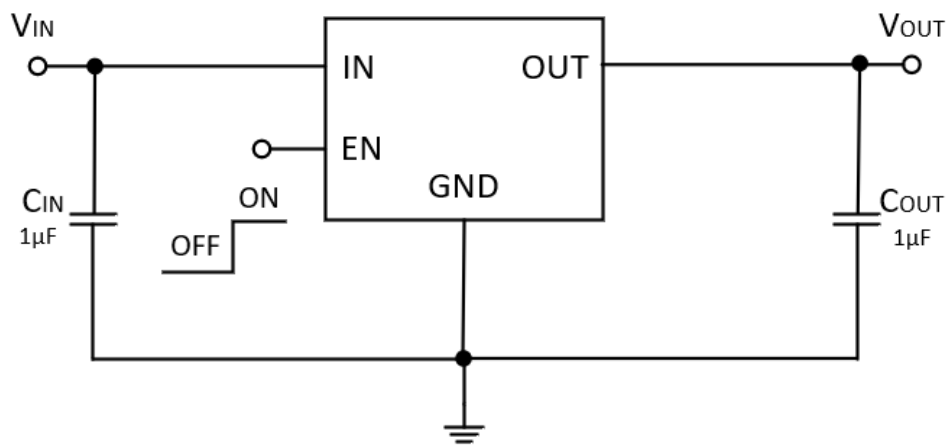

Pin Configuration

(Top View)

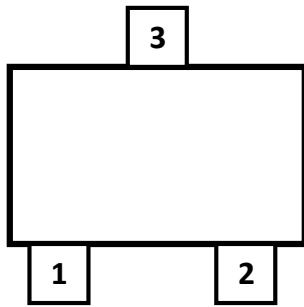

SOT23-3

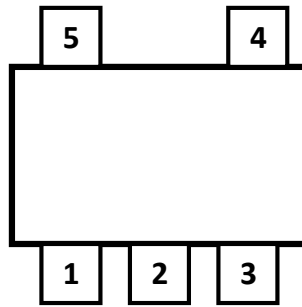

SOT23-5

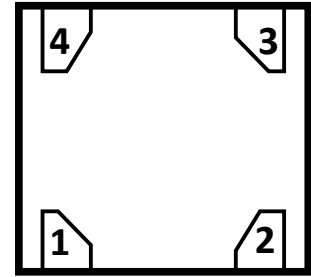

DFN-4

Pin Description

Pin Number			Pin Name	Description
SOT23-3	SOT23-5	DFN-4		
3	1	4	IN	Input Voltage
1	2	2	GND	Ground
-	3	3	EN	Enable, Active High
-	4	-	NC	NC
2	5	1	OUT	Output Voltage

Absolute Maximum Ratings

Parameter		Rating	Unit
Input voltage range		-0.3 ~ 6.0	V
EN Input voltage range		-0.3 ~ 6.0	V
Output voltage range		-0.3 to $V_{IN} + 0.3$	V
Power Dissipation P_D @ $T_A = 25^\circ\text{C}$		500	mW
Thermal Resistance, θ_{JA}		250	$^\circ\text{C}/\text{W}$
Operating Junction Temperature		150	$^\circ\text{C}$
Lead Temperature Range		260	$^\circ\text{C}$
Storage Temperature Range		-55 ~ 150	$^\circ\text{C}$
ESD Susceptibility	HBM	± 4000	V

Recommended Operating Conditions

Parameter		Rating	Unit
Operating Supply voltage		2.2 ~ 5.5	V
Operating Temperature Range		-40 ~ 85	$^\circ\text{C}$

Electrical Characteristics

($T_A = +25^{\circ}\text{C}$, $V_{IN}=V_{OUT}+1\text{V}$, $C_{IN}=C_{OUT}=1.0\mu\text{F}$, $I_{OUT}=1\text{mA}$, unless otherwise noted)

symbol	Parameter	Test Condition	Min	Typ	Max	Unit
V_{OUT}	Output Voltage		0.99 V_{OUT}	V_{OUT}	1.01 V_{OUT}	V
I_{OUT}	Maximum Output Current ¹		150	-	-	mA
I_{SHORT}	Short Current	V_{OUT} Short to GND	-	225	-	mA
V_{DO}	Dropout Voltage	$I_{OUT}=150\text{mA}@V_{OUT}=3\text{V}^2$	-	170		mV
LNR	Line Regulation	$V_{OUT}+1 < V_{IN} \leq 5.5\text{V}$, $I_{OUT}=1\text{mA}$	-	0.05	0.20	%/V
LDR	Load Regulation	$0\text{mA} < I_{OUT} \leq 150\text{mA}$, $V_{IN}=V_{OUT}+1\text{V}^3$	-	15		mV
I_Q	Quiescent Current	$I_{OUT}=0\text{mA}$	-	0.8	1	μA
I_{SHDN}	Shut-down Current	$V_{EN}=0\text{V}$	-	0.1	0.5	μA
PSRR	Power Supply Ripple Rejection	$f=1\text{KHz}$, $V_{IN}=V_{OUT}+1\text{V}$ $+200\text{mVpp}$ Modulation, $I_{OUT}=10\text{mA}$	-	45	-	dB
V_{NO}	Output noise voltage	$V_{IN}=5.0\text{V}$, $f=10\text{Hz}$ to 1MHz , $C_{OUT}=1\mu\text{F}$, $I_{OUT}=1\text{mA}$, $V_{OUT}=1.8\text{V}$	-	95	-	μV_{RMS}
V_{IH}	EN logic high voltage	$V_{IN}=5.5\text{V}$, $I_{OUT}=1\text{mA}$	1.2	-	-	V
V_{IL}	EN logic low voltage	$V_{IN}=5.5\text{V}$, $I_{OUT}=0\text{mA}$	-	-	0.4	V
I_{EN}	EN Input leakage	$V_{EN} \leq V_{IN} \leq 5.5\text{V}^4$	-	100	-	nA
R_{DIS}	Output Discharge Resistance	$V_{IN} = 5.5\text{V}$, $V_{EN} = 0\text{V}^4$	-	140	-	Ω
T_{SD}	Thermal Shutdown Temperature	Temperature Increasing from $T_J=+25^{\circ}\text{C}^4$	-	165	-	$^{\circ}\text{C}$
ΔT_{SD}	Thermal Shutdown Hysteresis	Temperature Falling from T_{SD}^4	-	20	-	$^{\circ}\text{C}$

Note1: Respect SOA.

Note 2: Characterized when V_{OUT} falls $V_{OUT} \cdot 3\%$ below the regulated voltage.

Note 3: The Load regulation is measured by using pulse techniques with the duty cycle $< 5\%$.

Note 4: Guaranteed by design and characterization.

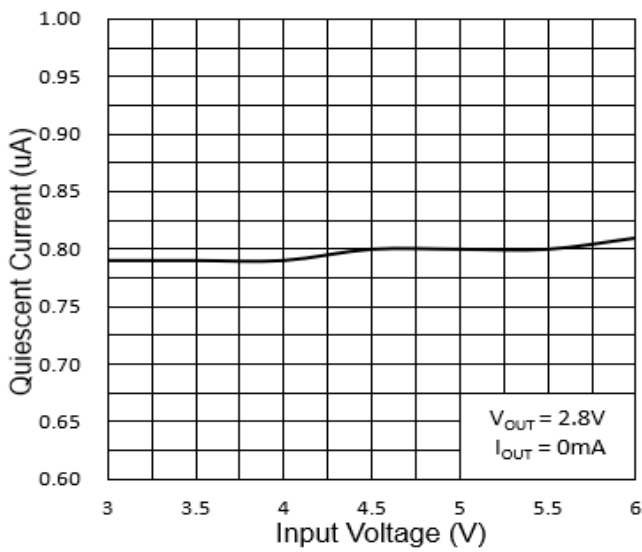
Typical Characteristics ($T_a=25^\circ\text{C}$, $V_{IN}=V_{OUT}+1\text{V}$, $C_{IN}=C_{OUT}=1\mu\text{F}$, unless otherwise noted)

Quiescent Current vs. Supply Voltage

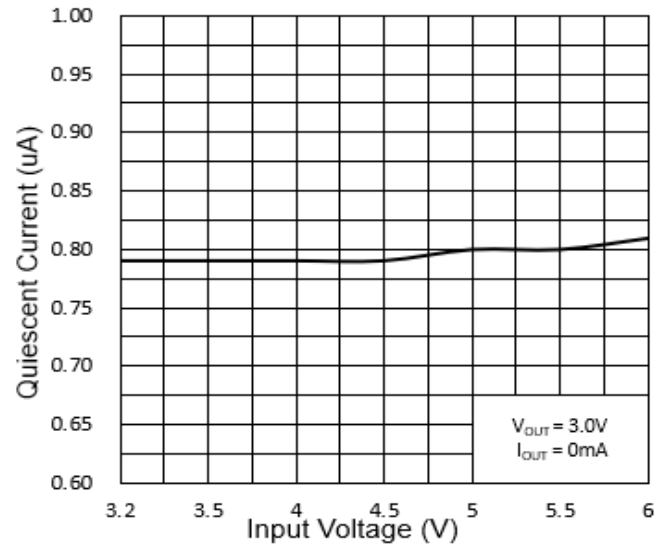

Quiescent Current vs. Supply Voltage

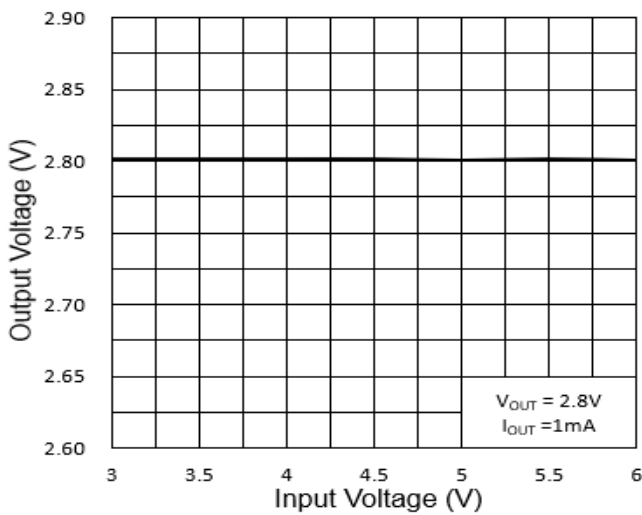

Output Voltage vs. Supply Voltage

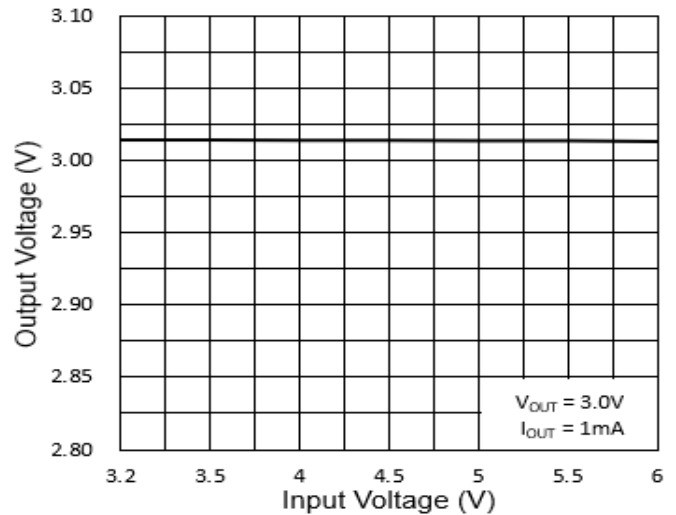

Output Voltage vs. Supply Voltage

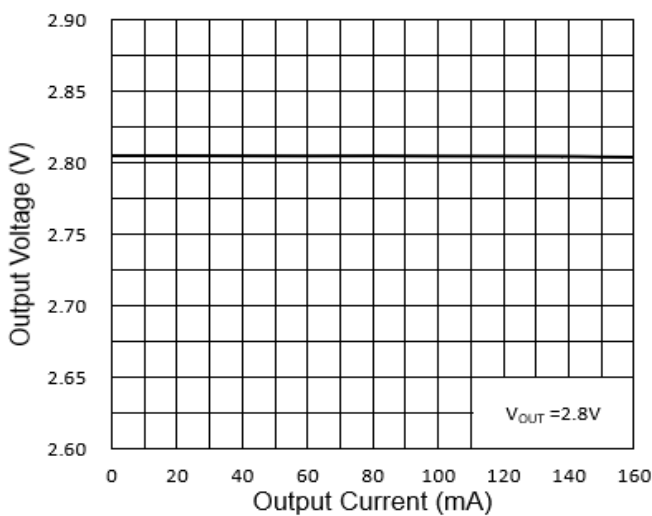

Output Voltage vs. Output Current

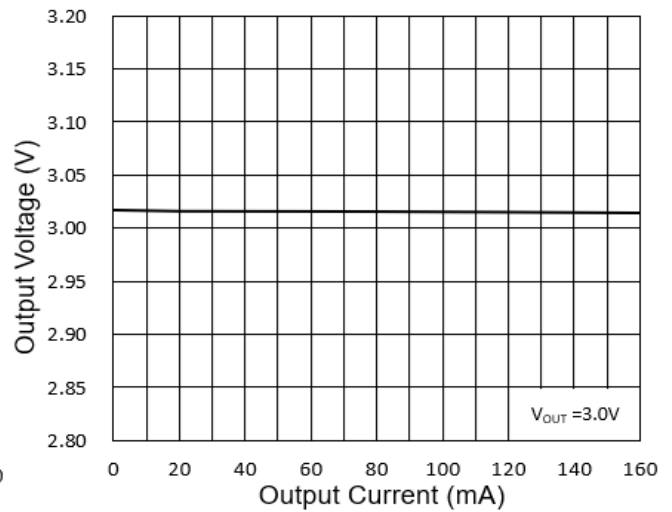

Output Voltage vs. Output Current

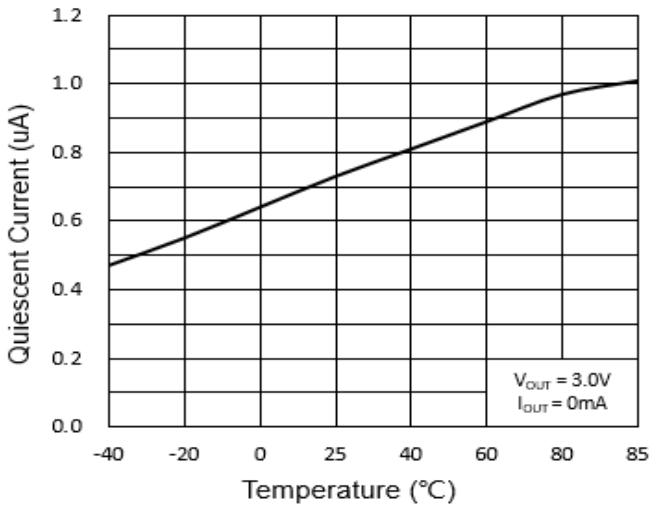

Quiescent Current vs. Temperature

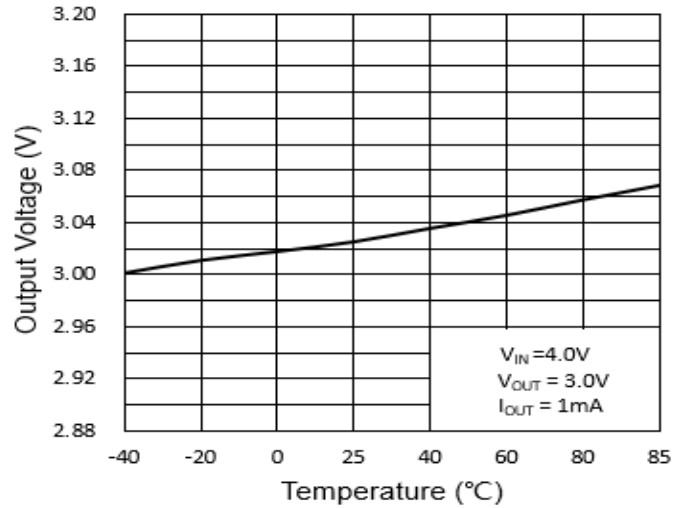

Output Voltage vs. Temperature

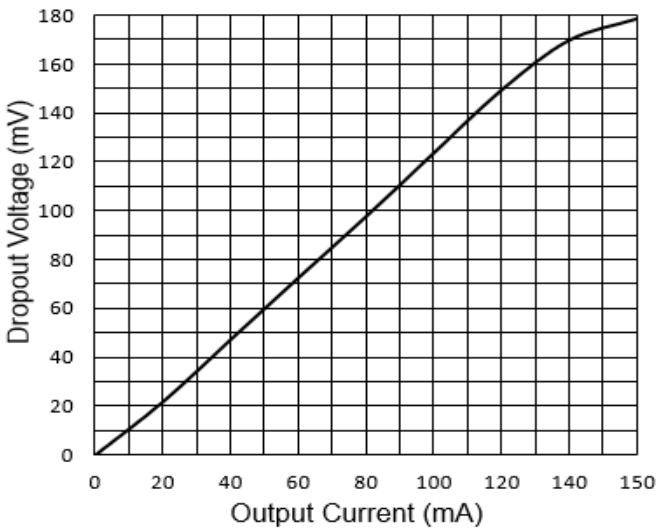

Dropout Voltage vs. Output Current
($V_{OUT} = 2.8V$)

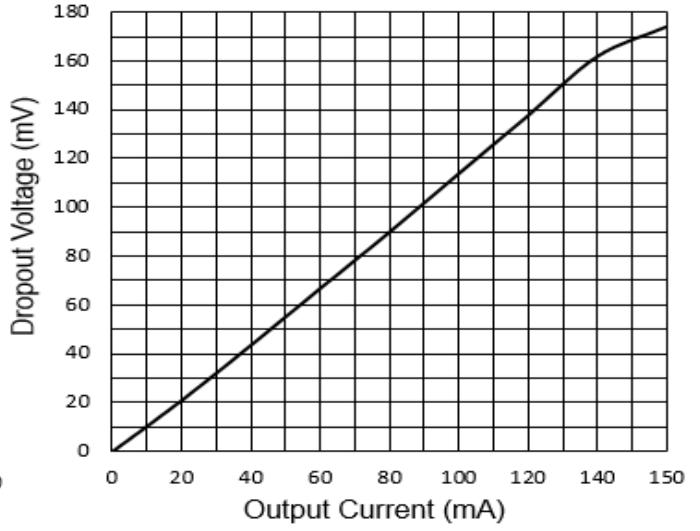

Dropout Voltage vs. Output Current
($V_{OUT} = 3.0V$)

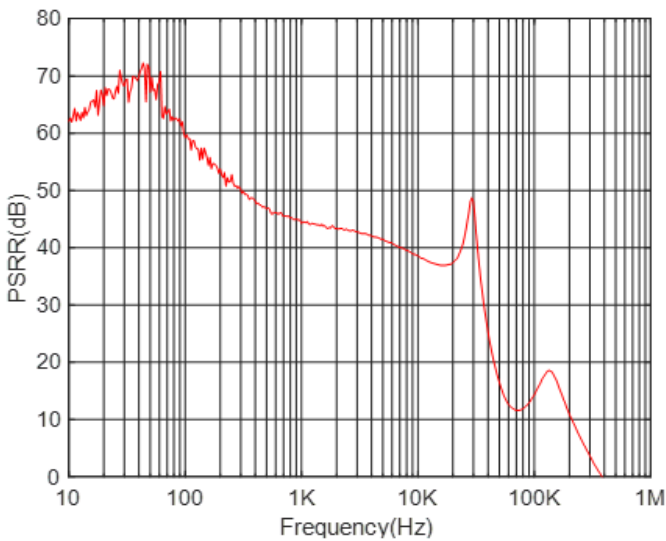

Power Supply Rejection Ratio vs. Frequency
($V_{OUT} = 2.8V$)

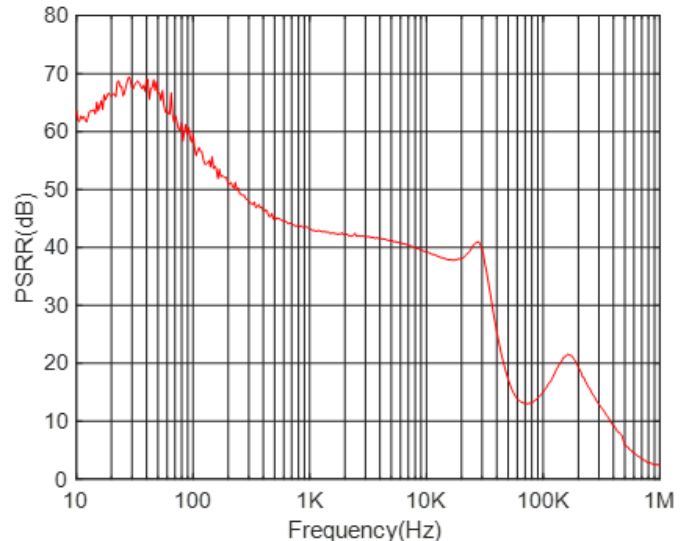

Power Supply Rejection Ratio vs. Frequency
($V_{OUT} = 3.0V$)

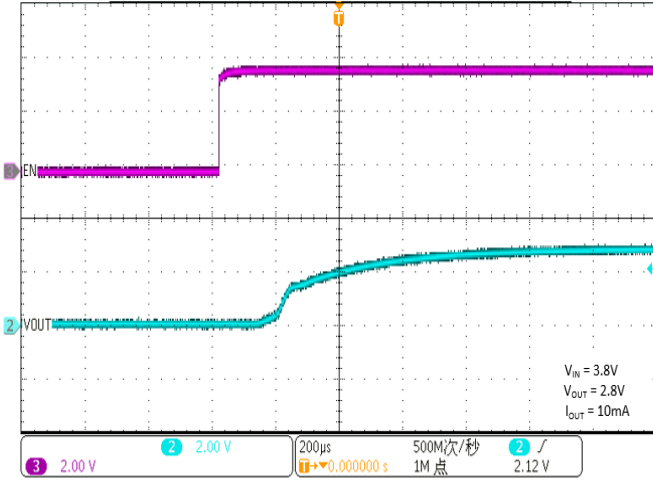

Start from EN

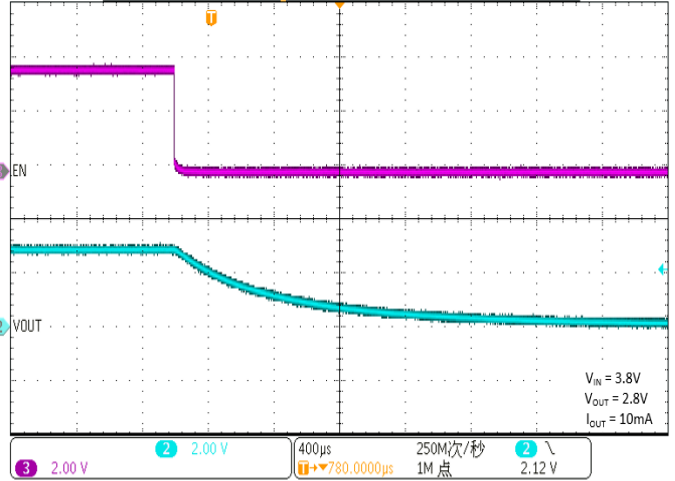

EN Shutdown

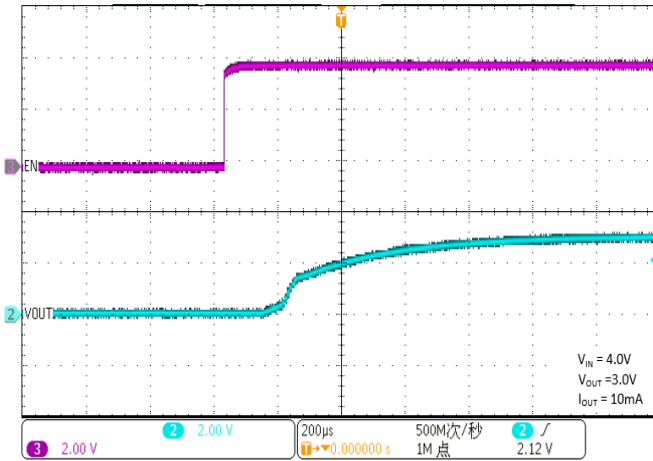

Start from EN

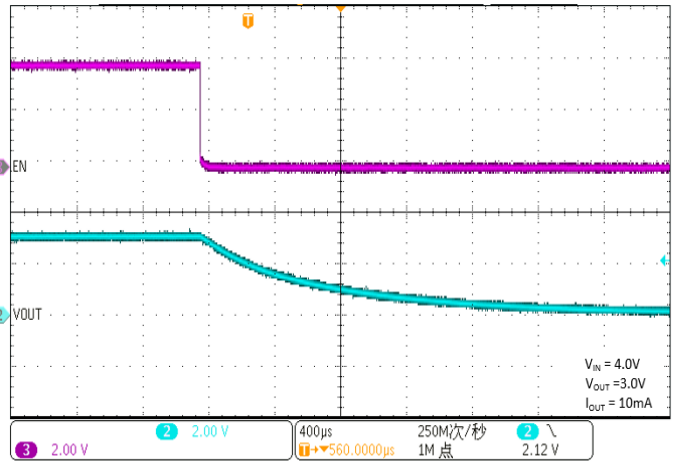

EN Shutdown

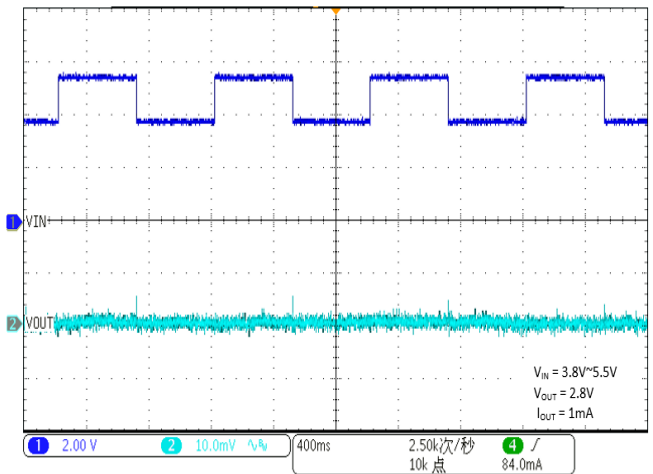

Line Transient

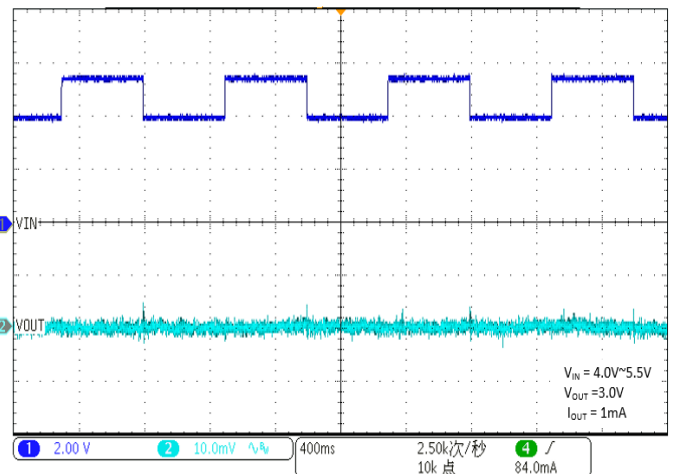

Line Transient

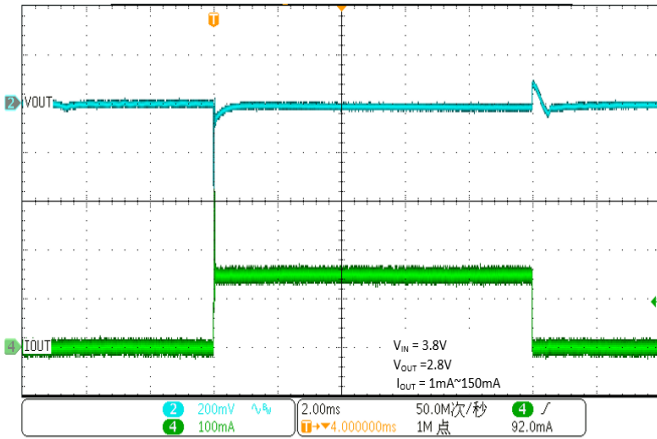

Load Transient

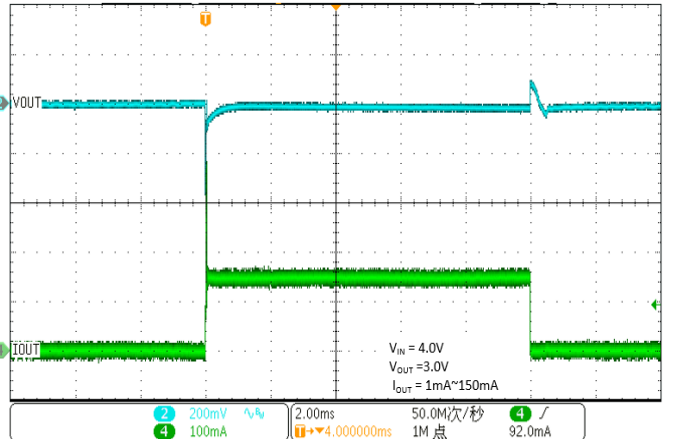

Load Transient

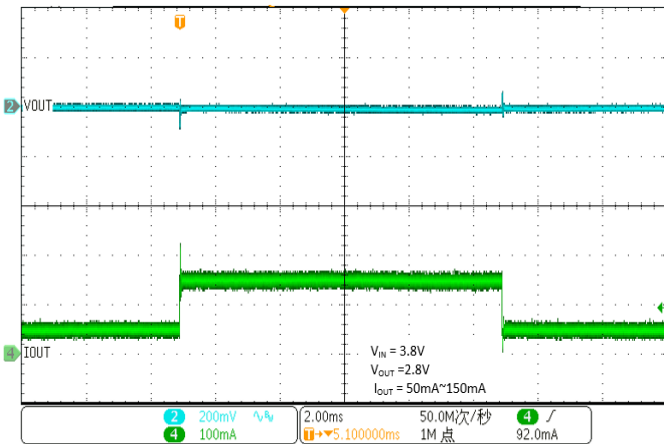

Load Transient

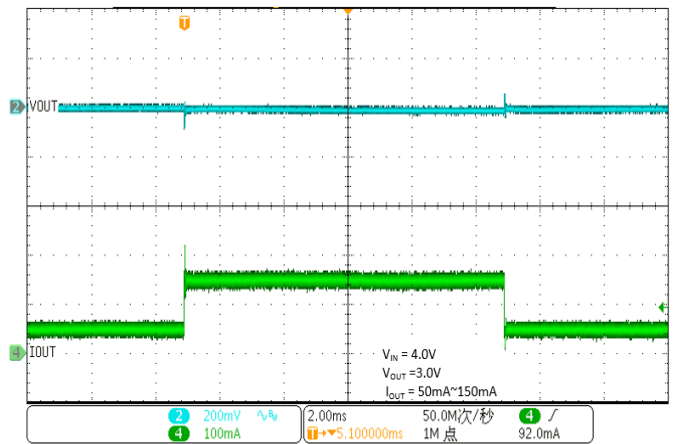

Load Transient

Block Diagram

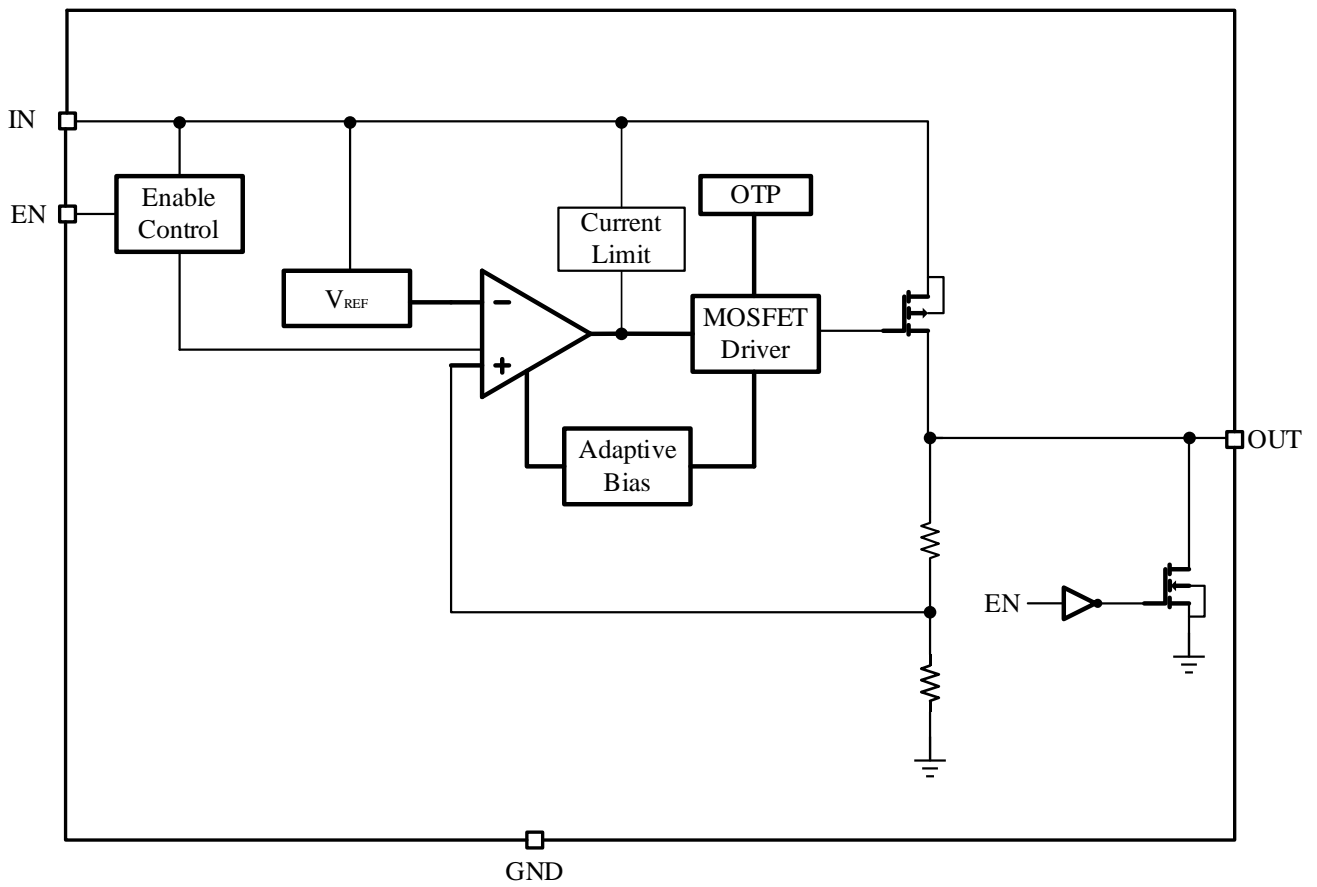

Package Information

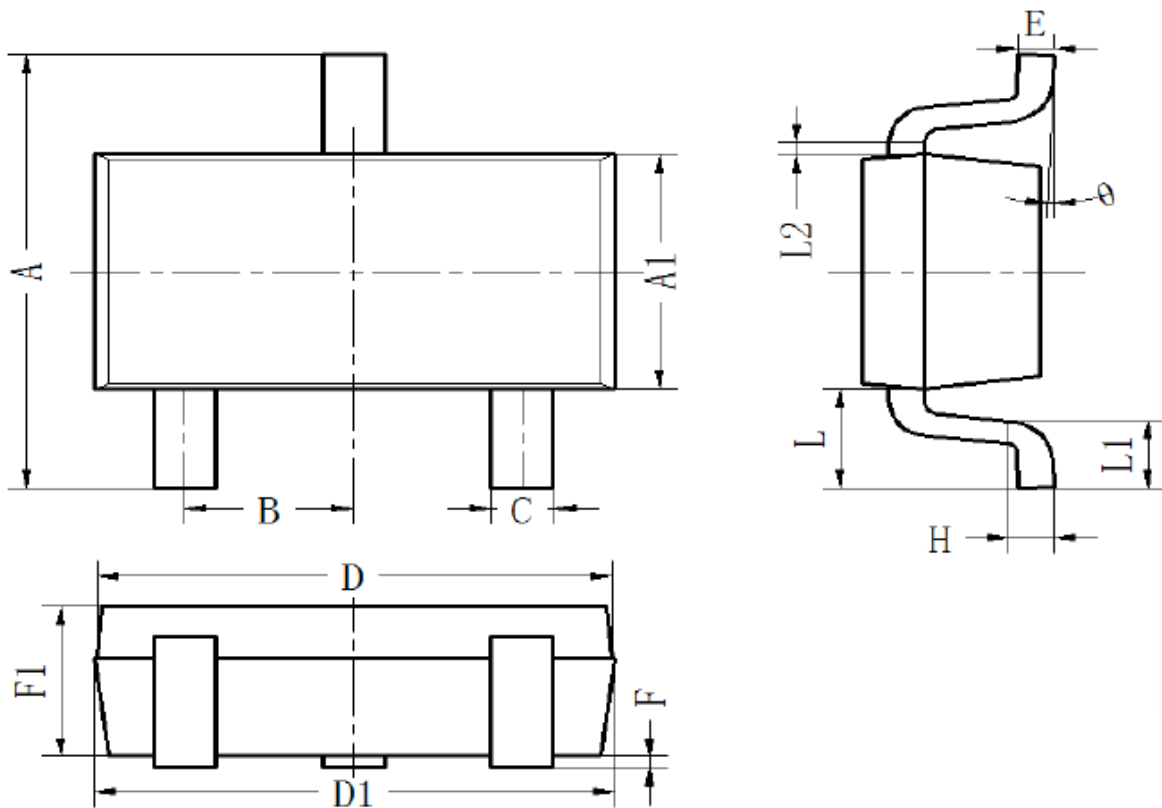

SOT 23-3

SYMBOL	DIMENSIONS IN MILLIMETERS		
	MIN	NOM	MAX
A	2.65	2.8	2.95
A1	1.5	1.6	1.7
B	0.90	0.95	1.00
C	0.3	0.4	0.5
D	2.82	2.92	3.02
D1	2.87	2.92	2.97
E	0.1	0.15	0.2
H	0.204	0.254	0.304
L	0.55	0.65	0.75
L1	0.3	0.45	0.6
L2	0.06	0.08	0.10
F1	1.05	1.1	1.15
F	0.02	0.08	0.15

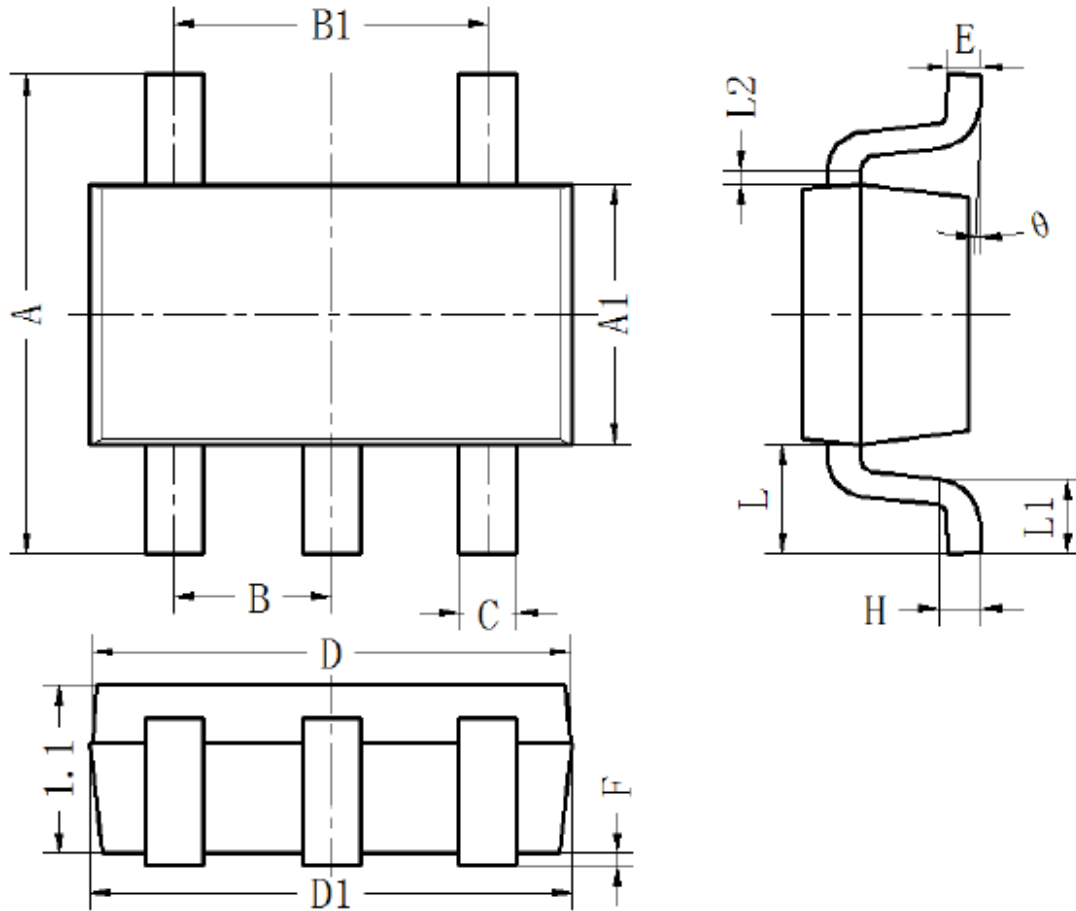

SOT 23-5

SYMBOL	DIMENSIONS IN MILLIMETERS		
	MIN	NOM	MAX
A	2.8	2.9	3.0
A1	1.5	1.6	1.7
B	0.90	0.95	1.0
B1	1.8	1.9	2.0
C	0.35	0.4	0.45
D	2.79	2.89	2.99
D1	2.82	2.92	3.02
E	0.1	0.15	0.2
F	0.02	0.08	0.14
H	0.254	0.254	0.254
L	0.55	0.65	0.75
L1	0.35	0.45	0.55
L2	0.08	0.08	0.08
θ	2		8

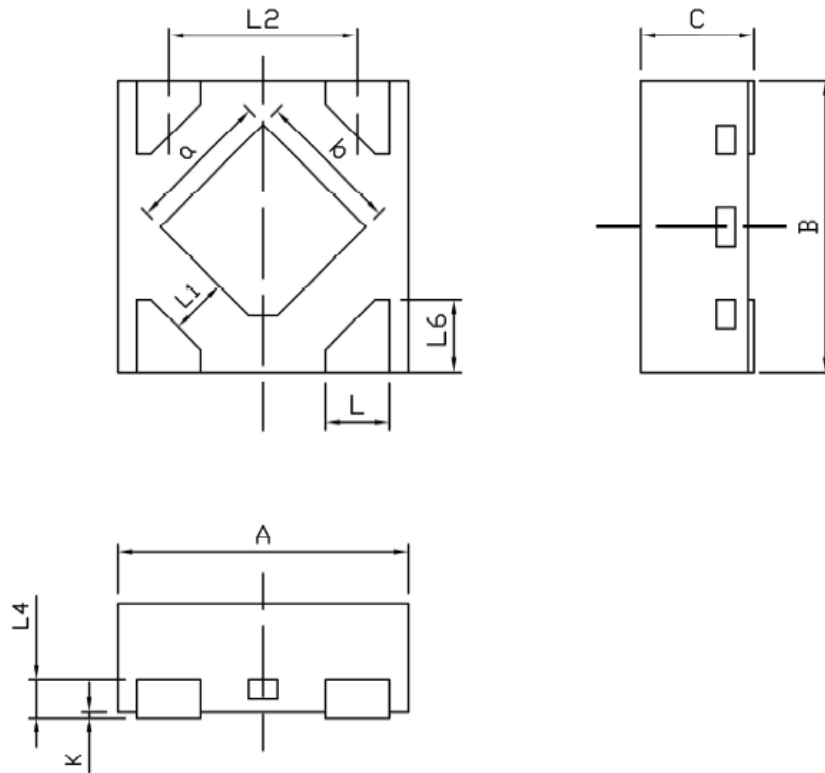

DFN-4

SYMBOL	DIMENSIONS IN MILLIMETERS		
	MIN	NOM	MAX
A	0.95	1.00	1.05
B	0.95	1.00	1.05
C	0.34	0.37	0.40
L	0.17	0.22	0.27
L1	0.15	-	-
L2	-	0.65	-
L4	-	0.10	-
L6	0.20	0.25	0.30
K	0	0.02	0.05
a	0.43	0.48	0.53
b	0.43	0.48	0.53

Ordering Information

Part Number	Output Voltage	Package	Packing Quantity	Marking*
WR0114-12A30R	1.2V	SOT23-3	3K/Reel	WR0114 12 XXXX
WR0114-15A30R	1.5V	SOT23-3	3K/Reel	WR0114 15 XXXX
WR0114-18A30R	1.8V	SOT23-3	3K/Reel	WR0114 18 XXXX
WR0114-25A30R	2.5V	SOT23-3	3k/Reel	WR0114 25 XXXX
WR0114-28A30R	2.8V	SOT23-3	3k/Reel	WR0114 28 XXXX
WR0114-30A30R	3.0V	SOT23-3	3k/Reel	WR0114 30 XXXX
WR0114-33A30R	3.3V	SOT23-3	3k/Reel	WR0114 33 XXXX
WR0114-12A50R	1.2V	SOT23-5	3k/Reel	WR0114 12 XXXX
WR0114-15A50R	1.5V	SOT23-5	3k/Reel	WR0114 15 XXXX
WR0114-18A50R	1.8V	SOT23-5	3K/Reel	WR0114 18 XXXX
WR0114-25A50R	2.5V	SOT23-5	3k/Reel	WR0114 25 XXXX
WR0114-28A50R	2.8V	SOT23-5	3K/Reel	WR0114 28 XXXX
WR0114-30A50R	3.0V	SOT23-5	3k/Reel	WR0114 30 XXXX
WR0114-33A50R	3.3V	SOT23-5	3k/Reel	WR0114 33 XXXX
WR0114-12FF4R	1.2V	DFN-4	10k/Reel	114 12
WR0114-15FF4R	1.5V	DFN-4	10k/Reel	114 15
WR0114-18FF4R	1.8V	DFN-4	10k/Reel	114 18
WR0114-25FF4R	2.5V	DFN-4	10k/Reel	114 25
WR0114-28FF4R	2.8V	DFN-4	10k/Reel	114 28
WR0114-30FF4R	3.0V	DFN-4	10k/Reel	114 30
WR0114-33FF4R	3.3V	DFN-4	10k/Reel	114 33

* XXXX is variable.

Contact Information

No.1001, Shiwan(7) Road, Pudong District, Shanghai, P.R.China.201202

Tel: 86-21-68960674 Fax: 86-21-50757680 Email: market@way-on.com

WAYON website: <http://www.way-on.com>

For additional information, please contact your local Sales Representative.

 is registered trademark of Wayon Corporation.

Specifications are subject to change without notice.

The device characteristics and parameters in this data sheet can and do vary in different applications and actual device performance may vary over time

Users should verify actual device performance in their specific applications.