

## 2A, 75V, 200kHz Step-Down Converter

### FEATURES

- Wide 4.5V to 75V Operating Input Range
- Output Adjustable from 0.8V to 50V
- Standby Current 400 $\mu$ A
- Power Save Mode at Light Load
- Programmable Maximum Peak Current
- 130m $\Omega$  Internal Power MOSFET Switch
- 91.8% Efficiency at  $V_{IN}=72V$ ,  $V_{OUT}=12V@1.2A$
- 81.4% Efficiency at  $V_{IN}=72V$ ,  $V_{OUT}=5V@0.8A$
- Fixed 200kHz Frequency
- Thermal Shutdown
- Cycle-by-Cycle Over Current Protection
- Available in SOP-8 Exposed Pad Package

### DESCRIPTION

The AIC2972 is a monolithic step-down switch mode converter. It achieves 2A continuous output current over a wide input supply range with excellent load and line regulation.

The maximum peak current can be programmed by sensing current through an accurate sense resistor.

Fault condition protection includes cycle-by-cycle current limiting and thermal shutdown.

The AIC2972 requires a minimum number of readily available standard external components. The AIC2972 is available in SOP-8 exposed pad package.

### APPLICATIONS

- Balance Bike
- Ebike
- USB Power Supplies

### APPLICATIONS CIRCUIT

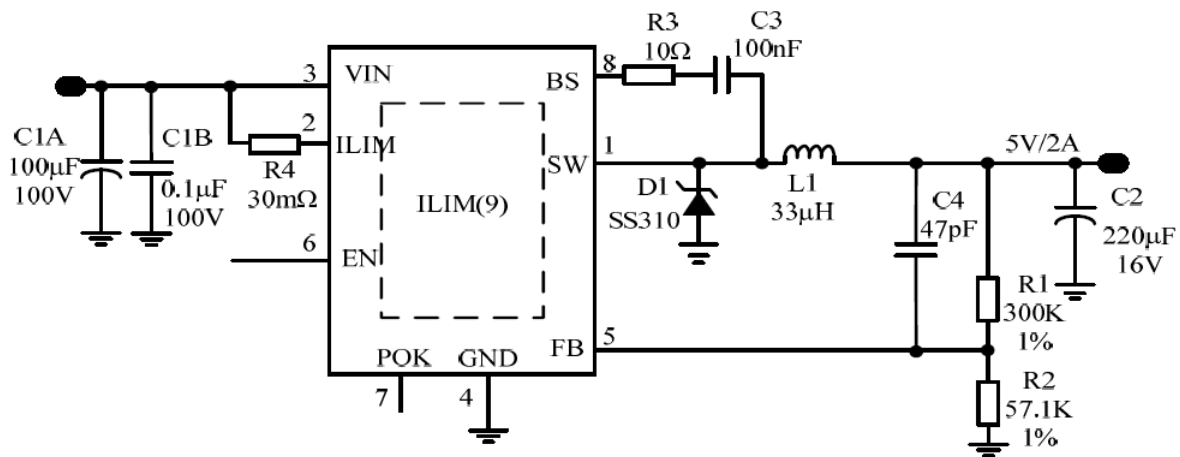

Typical Application Circuit

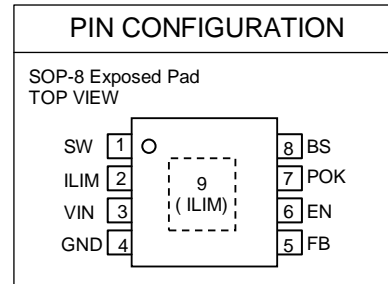
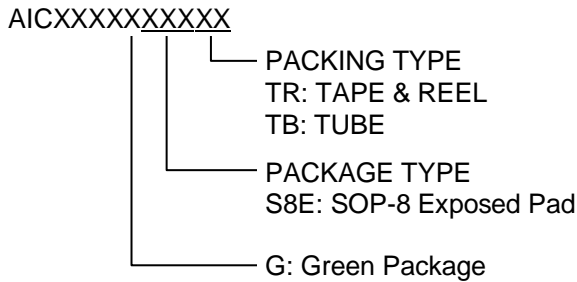
**ORDERING INFORMATION**

Example: AIC2972GS8ETR  
 → Green SOP-8 Exposed Pad Package  
 and Tape & Reel Packing Type

**ABSOLUTE MAXIMUM RATINGS**

VIN Pin and ILIM Pin Voltage .....	76V
SW Pin Voltage .....	-0.3V to $V_{IN} + 0.3V$
BS Pin Voltage .....	$V_{SW} + 6.0V$
POK Pin Voltage .....	0V to 45V
All Other Pins Voltage .....	-0.3V to +6.5V
Junction Temperature.....	150°C
Lead Temperature .....	260°C
Storage Temperature Range .....	- 65°C ~ 150°C
Operating Ambient Temperature Range .....	- 40°C ~ 85°C
Thermal Resistance Junction to Case      SOP-8 Exposed Pad* .....	15°C/W
Thermal Resistance Junction to Ambient    SOP-8 Exposed Pad* .....	45°C/W

(Assume no Ambient Airflow)

**Absolute Maximum Ratings are those values beyond which the life of a device may be impaired.**

\* Measured on approximately 42x45mm<sup>2</sup> of 1 oz copper.

**■ ELECTRICAL CHARACTERISTICS**
**( $V_{IN}=12V$ ,  $T_A=25^{\circ}C$ , unless otherwise specified.) (Note1)**

PARAMETER	SYMBOL	CONDITIONS	MIN	TYP	MAX	UNITS
Supply Voltage	$V_{IN}$		4.5		75	V
Output Voltage	$V_{OUT}$		0.8		40	V
Feedback Voltage	$V_{FB}$	$4.5V \leq V_{IN} \leq 80V$	0.785	0.805	0.825	V
Feedback Bias Current	$I_{BIAS(FB)}$	$V_{FB} = 0.8V$		10		nA
Switch On Resistance	$R_{DS(ON)}$			130		m $\Omega$
Current Limit(Note 2)			1.2	1.35	1.5	A
Oscillator Frequency	$f_{SW}$	$V_{FB} = 0.6V$	160	200	240	kHz
Fold-Back Frequency		$V_{FB} = 0V$		70		kHz
Boot-Strap Voltage	$V_{BST} - V_{SW}$			6		V
Minimum On Time(Note 3)	$T_{ON}$	$V_{FB} = 1V$		100		ns
Under Voltage Lockout Threshold Rising			3.0	3.3	3.6	V
Under Voltage Lockout Threshold Hysteresis			200			mV
Supply Current (Quiescent)		$V_{EN} = 2V, V_{FB} = 1V$		400	700	$\mu A$
Thermal Shutdown(Note 3)				160		$^{\circ}C$

Note 1: Specifications are production tested at  $T_A=25^{\circ}C$ . Specifications over the  $-40^{\circ}C$  to  $85^{\circ}C$  operating temperature range are assured by design, characterization and correlation with Statistical Quality Controls (SQC).

Note 2: Sense resistor defined.

Note 3: Guaranteed by design.

**TYPICAL PERFORMANCE CHARACTERISTICS**

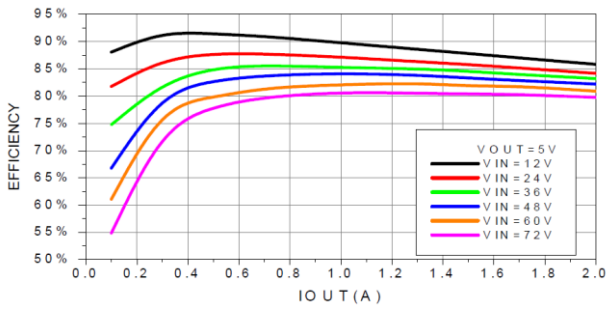

Fig. 1 Efficiency vs. Output Current

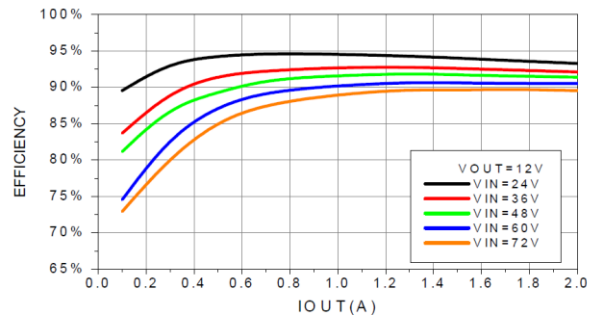

Fig. 2 Efficiency vs. Output Current

**■ PIN DESCRIPTIONS**

Pin No.	Pin Name	Pin Function
1	SW	Switch Output. Connect this pin to the switching end of the inductor.
2, 9	ILIM	Programmable maximum peak current pin by sensing current through an accurate sense resistor between this pin and VIN pin.
3	VIN	Supply Voltage. The AIC2972 operates from a +4.5V to +75V unregulated input. C <sub>IN</sub> is needed to prevent large voltage spikes from appearing at the input. Put C <sub>IN</sub> as close to the IC as possible. It is the drain of the internal power device and power supply for the whole chip.
4	GND	Ground. This pin is the voltage reference for the regulated output voltage. For this reason care must be taken in its layout. This node should be placed outside of the D <sub>1</sub> to C <sub>IN</sub> ground path to prevent switching current spikes from inducing voltage noise into the part.
5	FB	Feedback. An external resistor divider from the output to GND, tapped to the FB pin sets the output voltage. To prevent current limit run away during a short circuit fault condition the frequency-fold-back comparator lowers the oscillator frequency when the FB voltage is below 250mV.
6	EN	Enable pin. Connect to low off the chip, floating is enable.
7	POK	Power good signal. When FB is less than 90% of 0.8V, PGOOD is low. It is an open-drain output. Use a high value pull-up resistor externally to pull it up to system power supply or its output as next chip enable signal. Connected to GND or floating when don't use this function.
8	BS	Bootstrap. This pin acts as the positive rail for the high-side switch's gate driver. Connect a 100nF ceramic capacitor and 10ohm resistor between this pin and SW.

## ■ APPLICATION INFORMATION

### Main Control Loop

The AIC2972 is a current mode buck regulator. That is, the error amplifier (EA) output voltage is proportional to the peak inductor current. At the beginning of a cycle, the integrated high side power switch M1 is off; the EA output voltage is higher than the current sense amplifier output; and the current comparator's output is low. The rising edge of the 200kHz clock signal sets the RS Flip-Flop. Its output turns on M1 thus connecting the SW pin and inductor to the input supply.

The increasing inductor current is sensed and amplified by the Current Sense Amplifier. Ramp compensation is added to Current Sense Amplifier output and compared to the Error Amplifier output by the PWM Comparator. When the Current Sense Amplifier plus Slope Compensation signal exceeds the EA output voltage, the RS Flip-Flop is reset and the AIC2972 reverts to its initial M1 off state. If the Current Sense Amplifier plus Slope Compensation signal does not exceed the COMP voltage, then the falling edge of the CLK resets the Flip-Flop. The output of the Error Amplifier integrates the voltage difference between the feedback and the 0.8V bandgap reference. The polarity is such that a FB pin voltage, which is lower than 0.8V, increases the EA output voltage. Since the EA output voltage is proportional to the peak inductor current, an increase in its voltage increases current delivered to the output. An external Schottky Diode (D<sub>1</sub>) carries the inductor current when internal power MOS is off.

### Setting the Output Voltage

The external resistor divider is used to set the output voltage (see the schematic on front page). The feedback resistor R<sub>1</sub> also sets the feedback loop bandwidth with the internal compensation capacitor.

Choose R<sub>1</sub> to be around 300kΩ for optimal transient response. R<sub>2</sub> is then given by:

$$R_2 = \frac{R_1}{\frac{V_{OUT}}{0.805} - 1}$$

Table 1 Resistor Selection for Common

V <sub>OUT</sub> (V)	R <sub>1</sub> (kΩ)	R <sub>2</sub> (kΩ)
3.3	300(1%)	96(1%)
5	300(1%)	57.1(1%)
12	300(1%)	21.4(1%)
15	300(1%)	16.9(1%)
24	300(1%)	10.2(1%)
32	300(1%)	7.6(1%)

### Selecting the Inductor

33μH to 100μH inductor with a DC current rating of at least 30% percent higher than the maximum load current is recommended for most applications. For highest efficiency, the inductor DC resistance should be less than 50mΩ. For most designs, the inductance value can be derived from the following equation.

$$L = \frac{V_{OUT} \times (V_{IN} - V_{OUT})}{V_{IN} \times \Delta I_L \times f_{SW}}$$

Where ΔI<sub>L</sub> is the inductor ripple current. Choose inductor current ripple to be approximately 30%~40% of the maximum load current. The maximum inductor peak current is:

$$I_{L(MAX)} = I_{OUT(MAX)} + \frac{\Delta I_L}{2}$$

Under light load conditions below 100mA, larger inductance is recommended for improved efficiency.

### Selecting the Input Capacitor

The input capacitor reduces the surge current drawn from the input and also the switching noise from the device. The input capacitor impedance at the switching frequency should be less than the input

source impedance to prevent high frequency switching current from pass to the input. For most applications, a 47 $\mu$ F to 100 $\mu$ F electrolytic capacitor is sufficient.

### Selecting the Output Capacitor

The output capacitor keeps output voltage ripple small and ensures regulation loop stability. The output capacitor impedance should be low at the switching frequency. A 220 $\mu$ F electrolytic capacitor is recommended.

### ILIM sense resistor

Power current flows into the chip via the external accuracy sense resistor which defined the maximum peak current. In guarantee under the normal start up with full load, the sense resistor is recommended use the larger value to ensure less surge current and output short power dissipation. The sense resistor value should be reduced when used it at low temperature situation to ensure enough startup energy.

Table 2 Sense Resistor Selection

Max. output current (A)	R <sub>sense</sub> (m $\Omega$ )
0.8	50
1.0	40
2.0	30

### Loop compensation

A 12pF to 82pF ceramic capacitor connected between FB and OUT can optimize the loop stability for both bandwidth and phase margin, recommended a 22 pF to 47pF ceramic capacitor in most case.

### PCB Layout

(1) Under the large output current and high input voltage case, the schottky diode and the converter is the main heat source, don't put them too close, the PCB layout should keep enough area for heat dissipation. Recommended ratio is 6:4 for schottky

diode and the convertor, for the cost issues, the normal selection of PCB is 1oz thickness, the thick solder tin is benefit on heat dissipation.

(2) ILIM is internal connected the power MOS, the heat dissipation should be considered for this pin.

(3) The large current path (ILIM, SW) should be put closer the converter as possible, use short, straight, wide copper foil connect.

(4) Input capacitor should be put as close as possible to VIN pin and GND.

(5) The loop of input capacitor, internal power MOS and schottky diode is the highest di/dt radiation region, reduce this region as possible. A 0.1 $\mu$ F ceramic capacitor can be used to form a small loop with internal power MOS and schottky diode, which can reduce the switch ringing caused by PCB parasitic inductor.

(6) The outside feedback resistor should be placed nearby the FB pin and keep away from SW node.

(7) A 220pF ceramic capacitor between VIN and SW pin can be used to reduce the switch negative overshoot and improve EMI performance when needed.

Figures 3 to 5 show the layout diagrams of AIC2972.

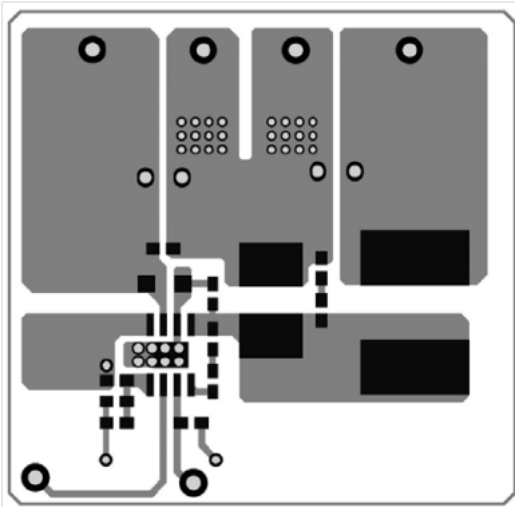

Fig. 3 Top Layer

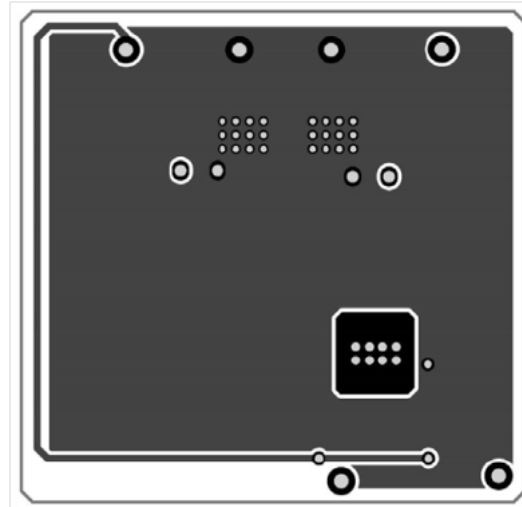

Fig. 4 Bottom Layer

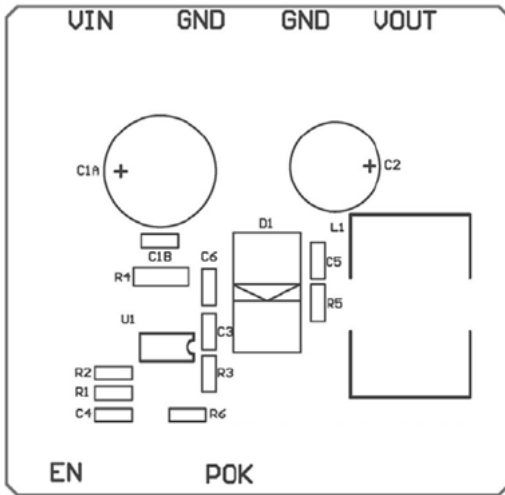

Fig. 5 Top Component Placement



**APPLICATION EXAMPLES**

Fig. 6 AIC2972 Application Circuit for 5V/2A Output Application

Table 3 BOM List for 5V/2A Output Application

Ref	Value	Description	Package	Manufacturer	Qty	Manufacturer P/N
C1A	100µF	Electrolytic, 100V	ELC SMD	jiang hai	1	VTD-100V100
C1B	0.1µF	Ceramic capacitor, 100V	0603	muRata	1	GRM188R71C104K
C2	220µF	Electrolytic, 16V	ELC SMD	jiang hai	1	VTD-100V220
C3	100nF	Ceramic capacitor, 100V, X7R	0603	muRata	1	GRM188R71C104K
C4	47pF	Ceramic, capacitor 25V, X7R	0603	muRata	1	GRM32DR71E470K
D1	3A	Schottky Diode, SMD, 100V, 3A	SMB		1	SS310
L1	33µH	Inductor CDRH104, 2.4A	CDRH104		1	
R1	300kΩ	Film Res., 1%	0603	Panasonic	1	ERJ-3EKF3003V
R2	57.1kΩ	Film Res., 1%	0603	Panasonic	1	ERJ-3EKF5712V
R3	10Ω	Film Res., 1%	0603	Panasonic	1	ERJ-3EKF0011V
R4	30mΩ	Film Res., 1%	1206		1	
U1		DC-DC convertor	SOP-8E	AIC2972	1	

**Note:** recommended to use a low  $V_F$  schottky diode for efficiency promotion.

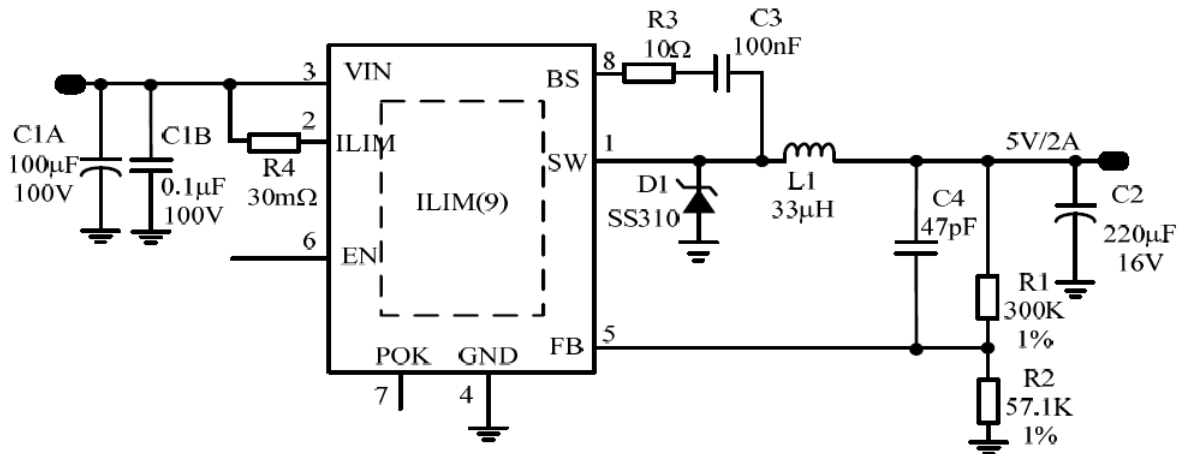
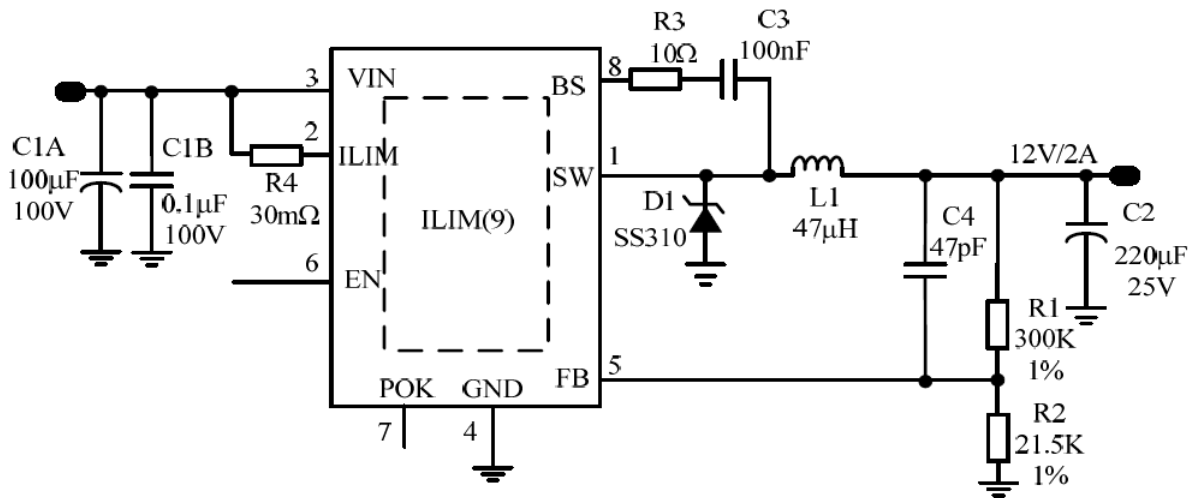

Fig. 7 AIC2972 Application Circuit for 12V/2A Output Application

Table 4 BOM List for 12V/2A Output Application

Ref	Value	Description	Package	Manufacturer	Qty	Manufacturer P/N
C1A	100µF	Electrolytic, 100V	ELC SMD	jiang hai	1	VTD-100V100
C1B	0.1µF	Ceramic capacitor, 100V	0603	muRata	1	GRM188R71C104K
C2	220µF	Electrolytic, 25V	ELC SMD	jiang hai	1	VTD-100V220
C3	100nF	Ceramic capacitor, 100V, X7R	0603	muRata	1	GRM188R71C104K
C4	47pF	Ceramic, capacitor 25V, X7R	0603	muRata	1	GRM32DR71E470K
D1	3A	Schottky Diode, SMD, 100V, 3A	SMB		1	SS310
L1	47µH	Inductor CDRH127, 2.5A	CDRH127		1	
R1	300KΩ	Film Res., 1%	0603	Panasonic	1	ERJ-3EKF3003V
R2	21.5KΩ	Film Res., 1%	0603	Panasonic	1	ERJ-3EKF2152V
R3	10Ω	Film Res., 1%	0603	Panasonic	1	ERJ-3EKF0011V
R4	30mΩ	Film Res., 1%	1206		1	
U1		DC-DC convertor	SOP-8E	AIC2972	1	

**Note:** recommended to use a low  $V_f$  schottky diode for efficiency promotion.

## PHYSICAL DIMENSIONS

### SOP-8 Exposed Pad

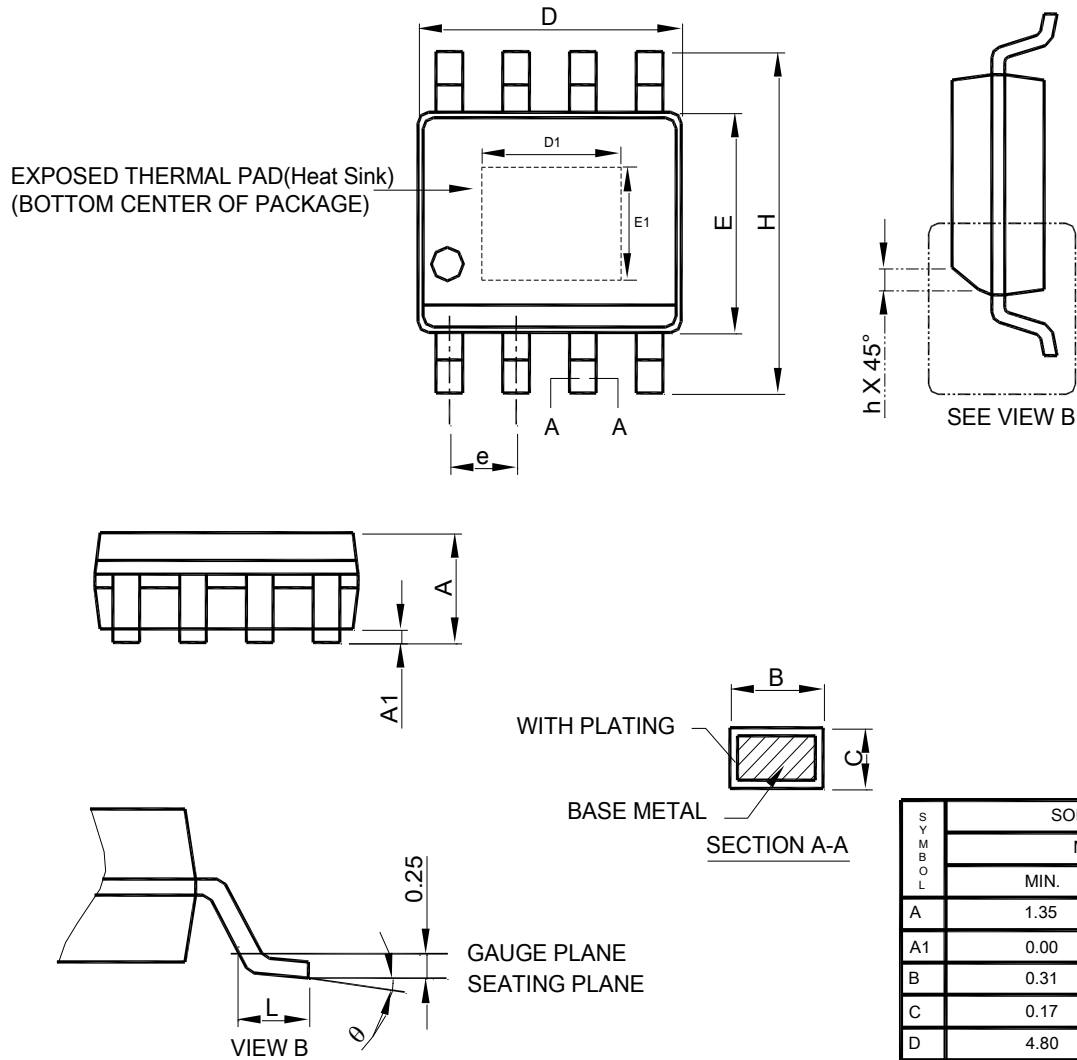

Note : 1. Refer to JEDEC MS-012E.

2. Dimension "D" does not include mold flash, protrusions or gate burrs. Mold flash, protrusion or gate burrs shall not exceed 6 mil per side .
3. Dimension "E" does not include inter-lead flash or protrusions.
4. Controlling dimension is millimeter, converted inch dimensions are not necessarily exact.

SYMBOL	SOP-8 Exposed Pad	
	MILLIMETERS	
	MIN.	MAX.
A	1.35	1.75
A1	0.00	0.15
B	0.31	0.51
C	0.17	0.25
D	4.80	5.00
D1	1.50	3.50
E	3.80	4.00
E1	1.0	2.55
e	1.27 BSC	
H	5.80	6.20
h	0.25	0.50
L	0.40	1.27
θ	0°	8°

### Note:

Information provided by AIC is believed to be accurate and reliable. However, we cannot assume responsibility for use of any circuitry other than circuitry entirely embodied in an AIC product; nor for any infringement of patents or other rights of third parties that may result from its use. We reserve the right to change the circuitry and specifications without notice.

Life Support Policy: AIC does not authorize any AIC product for use in life support devices and/or systems. Life support devices or systems are devices or systems which, (i) are intended for surgical implant into the body or (ii) support or sustain life, and whose failure to perform, when properly used in accordance with instructions for use provided in the labeling, can be reasonably expected to result in a significant injury to the user.