

## 100mA Ultra-low power consumption, CMOS LDO

### General Description

The WR0116 series is a set of low power high voltage regulators implemented in CMOS technology which can provide 100mA output current. The device allows input voltage as high as 30V.

The WR0116 series are available in wide output voltage range version from 2.1V to 12V.

The WR0116 series is available in Green SOT23-3L、SOT23-5L and SOT89-3L packages. It operates over an ambient temperature range of -40°C to +85°C.

### Feature

- Low Power Consumption
- Low Temperature Coefficient
- High Input Voltage (up to 30V)
- Output Current: 100mA
- Output Voltage Accuracy:  $\pm 3\%$
- Fixed Output Voltage Versions: 2.1V to 12V
- -40°C to +85°C Operating Temperature Range

### Applications

- Battery-Powered Equipment
- Communication Equipment
- Audio/Video Equipment

### Typical Application

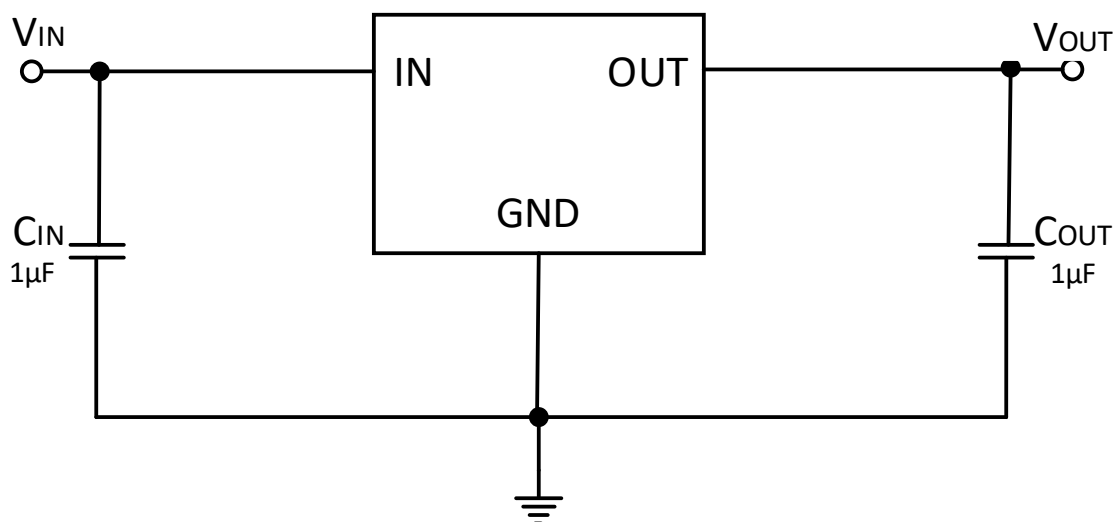

## Pin Configuration

(Top View)

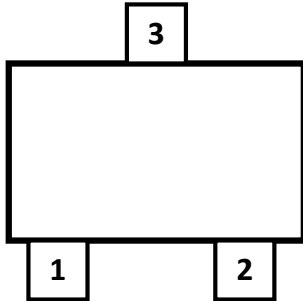

SOT23-3L

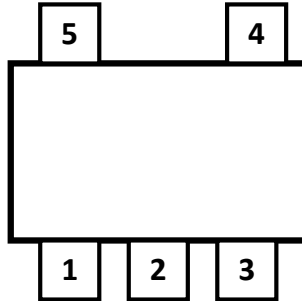

SOT23-5L

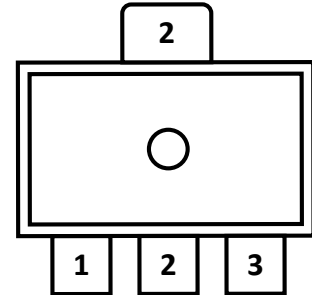

SOT89-3L

## Pin Description

Pin Name			Pin Number	Description
SOT23-5L	SOT23-3L	SOT89-3L		
1	1	1	GND	Ground
2	2	2	VIN	Regulator Input
3	3	3	VOUT	Regulator Output
4	-	-	NC	Not connect
5	-	-	NC	Not connect

**Absolute Maximum Ratings**

Parameter		Rating	Unit
Input voltage range		-0.3 ~ 33	V
Power Dissipation $P_D @ T_A = 25^\circ\text{C}$	SOT23-5L/SOT23-3L	500	mW
	SOT89-3L	625	mW
Thermal Resistance, $\theta_{JA}$	SOT23-5L/SOT23-3L	250	$^\circ\text{C/W}$
	SOT89-3L	200	$^\circ\text{C/W}$
Junction Temperature		150	$^\circ\text{C}$
Lead temperature (10s)		260	$^\circ\text{C}$
Storage Temperature Range		-55 ~ 150	$^\circ\text{C}$
ESD Susceptibility	HBM	$\pm 3000$	V

**Recommended Operating Conditions**

Parameter	Rating	Unit
Operating Supply Voltage	3.5 ~ 30	V
Operating Temperature Range	-40 ~ 85	$^\circ\text{C}$

## Electrical Characteristics

( $V_{IN}=V_{OUT}+2V$ , whichever is greater,  $C_{IN}=C_{OUT}=1\mu F$ , typical values are at  $T_A=+25\text{ }^\circ\text{C}$ , unless otherwise noted.)

symbol	Parameter	Test Condition	Min	Typ	Max	Unit
$V_{OUT}$	Output Voltage	$V_{IN}=V_{OUT}+2V$ , $I_{OUT}=1mA$	0.97 $V_{OUT}$	$V_{OUT}$	1.03 $V_{OUT}$	V
	Output Voltage Accuracy		-3		+3	%
$I_{OUT}$	Maximum Output Current	$V_{IN}=V_{OUT}+2V$	70	100	-	mA
$I_{SHORT}$	Short Current	$V_{OUT}=0V$		70		mA
$I_Q$	Quiescent Current	$V_{IN}=V_{OUT}+2V$ , $I_{OUT}=0mA$	-	2.5	4.0	$\mu A$
$V_{DO}$	Dropout Voltage <sup>1</sup>	$V_{OUT}=5.0V$ , $I_{OUT}=50mA$		230		mV
		$V_{OUT}=3.3V$ , $I_{OUT}=50mA$		270		
		$V_{OUT}=3.0V$ , $I_{OUT}=50mA$		290		
		$V_{OUT}=2.7V$ , $I_{OUT}=50mA$		310		
LNR	Line Regulation	$V_{OUT}+1V \leq V_{IN} \leq 30V$ , $I_{OUT}=1mA$			0.2	%/V
LDR	Load Regulation <sup>2</sup>	$V_{IN}=V_{OUT}+2V$ , $1mA \leq I_{OUT} \leq 100mA$		15	40	mV
PSRR	Power Supply Rejection Ratio	$V_{IN}=(V_{OUT}+1V)_{DC}+0.5V_{P-P}$ $F=1KHz$ , $I_{OUT}=10mA$ @ $V_{OUT}=3.3V$		37		dB
$\frac{\Delta V_{OUT}}{\Delta T_A \times V_{OUT}}$	Output Voltage Temperature Coefficient	$I_{OUT}=10mA$ , $-40^\circ\text{C} \leq T_A \leq 85^\circ\text{C}$		100		ppm/ $^\circ\text{C}$

Note1: The dropout voltage is defined as  $V_{IN}-V_{OUT}$ , when  $V_{OUT}$  is 98% of the value of  $V_{OUT}$  for  $V_{IN}=V_{OUT}+2V$ .

Note2: The Load regulation is measured using pulse techniques with duty cycle < 5%.

**Typical Characteristics**

( $T_a=25^\circ\text{C}$ ,  $V_{IN}=V_{OUT}+2\text{V}$ ,  $C_{IN}=C_{OUT}=1\mu\text{F}$ , unless otherwise noted)

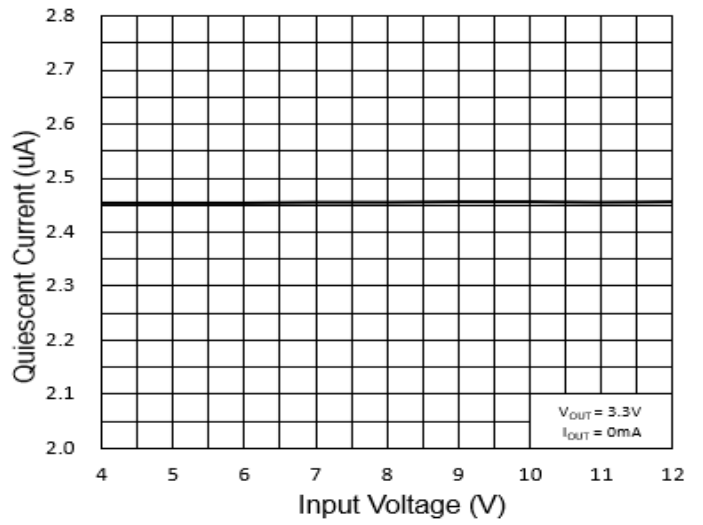
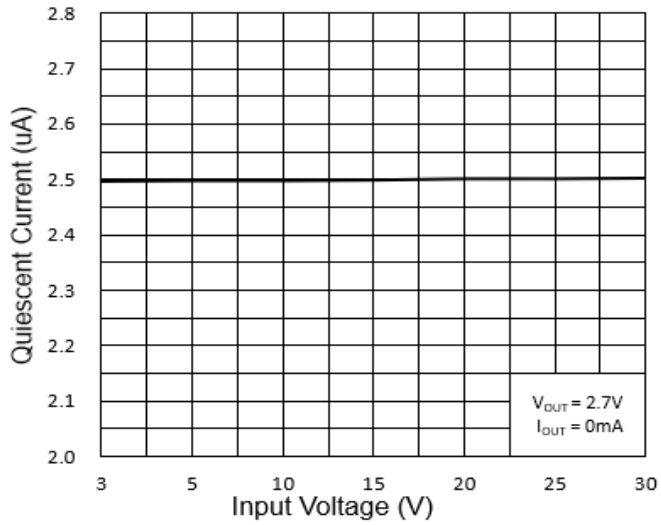

Quiescent Current vs. Supply Voltage

Quiescent Current vs. Supply Voltage

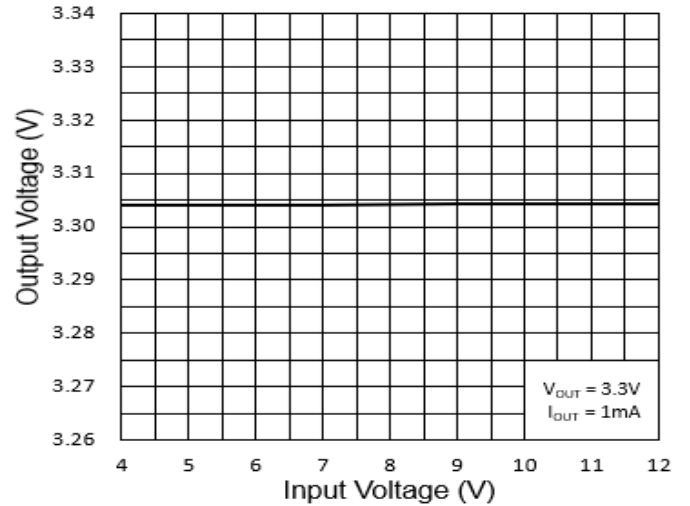
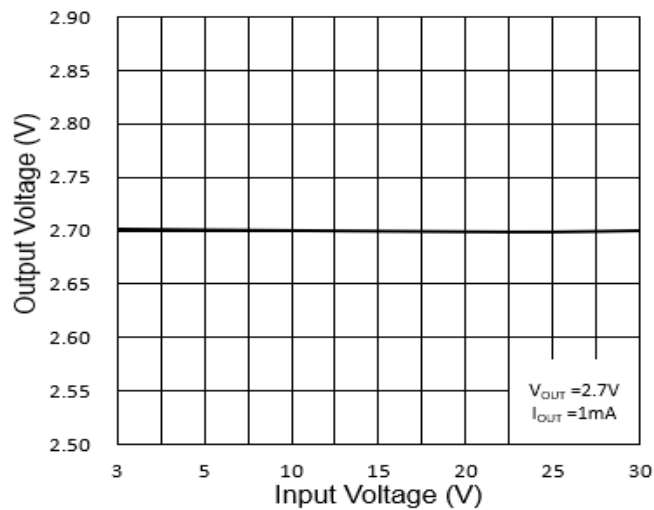

Output Voltage vs. Supply Voltage

Output Voltage vs. Supply Voltage

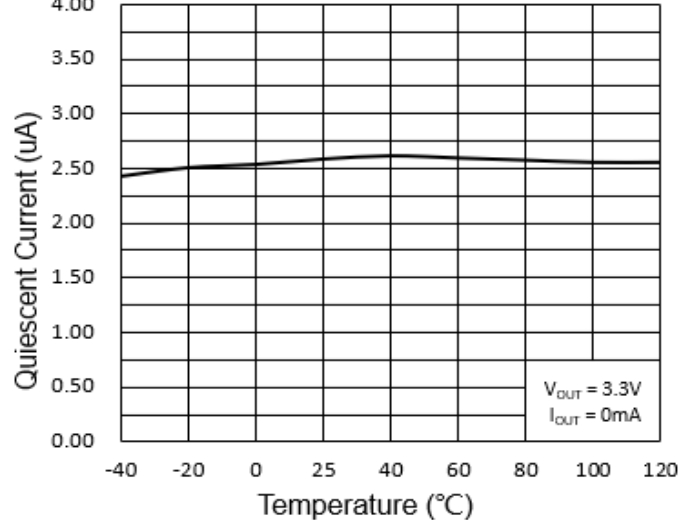
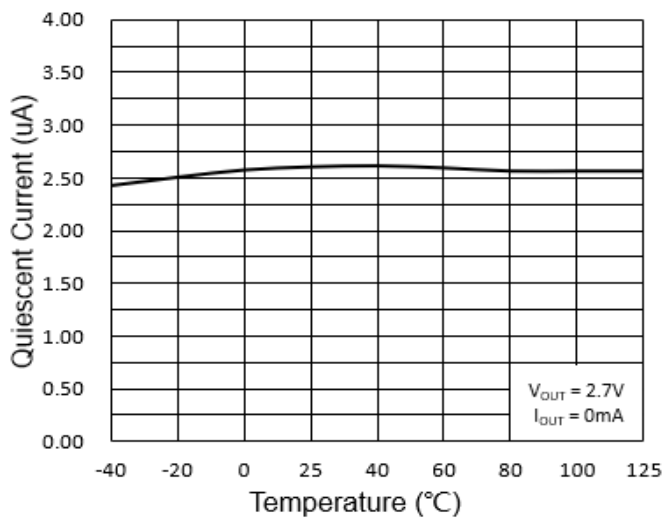

Quiescent Current vs. Temperature

Quiescent Current vs. Temperature

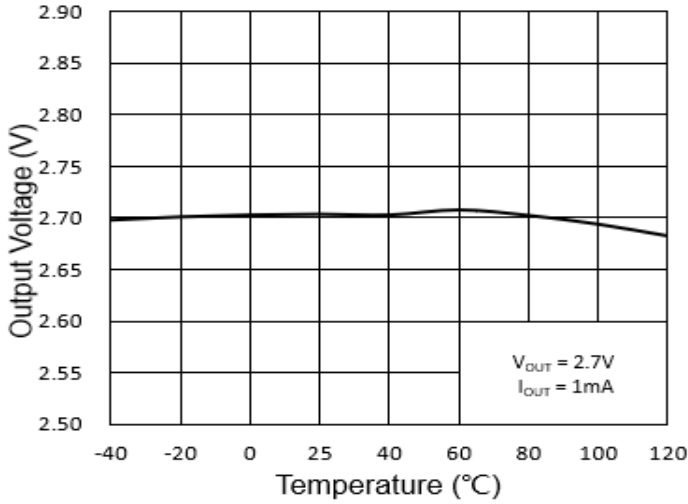

Output Voltage vs. Temperature

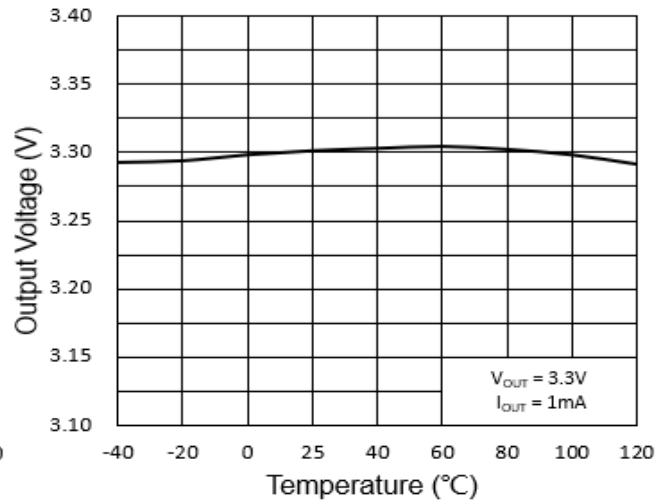

Output Voltage vs. Temperature

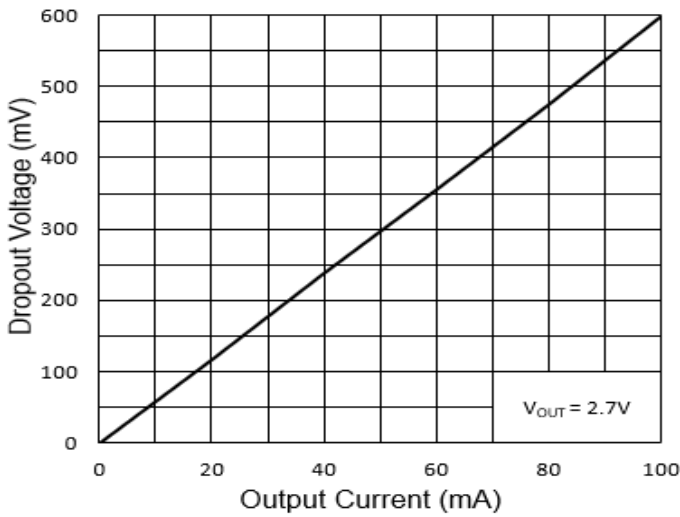

Dropout Voltage vs. Output Current

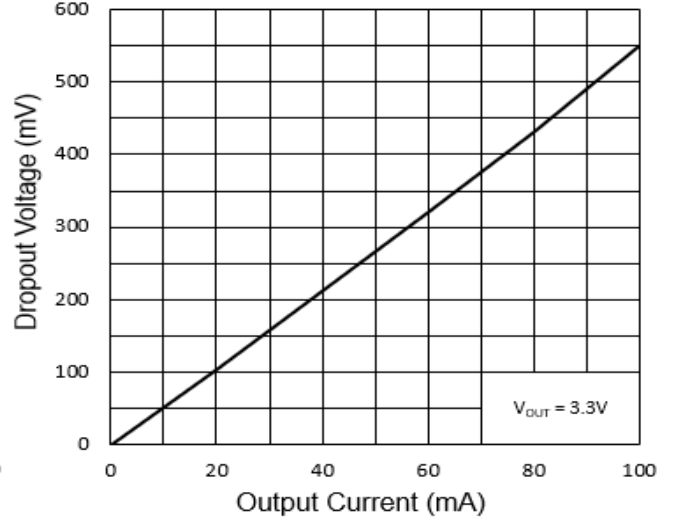

Dropout Voltage vs. Output Current

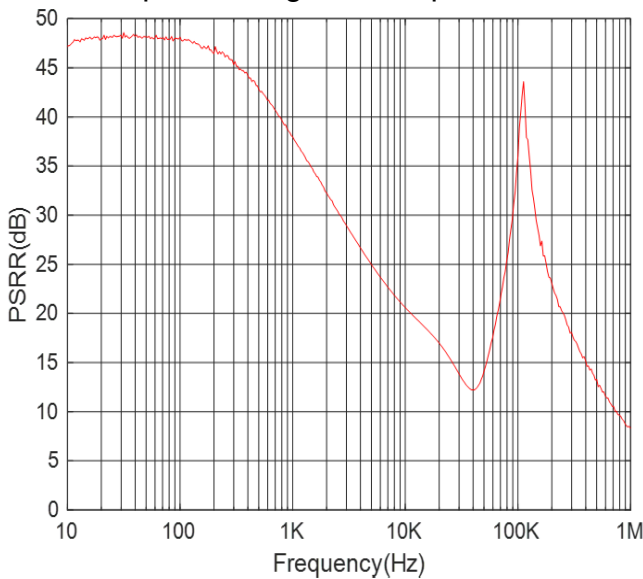

Power Supply Rejection Ratio vs. Frequency

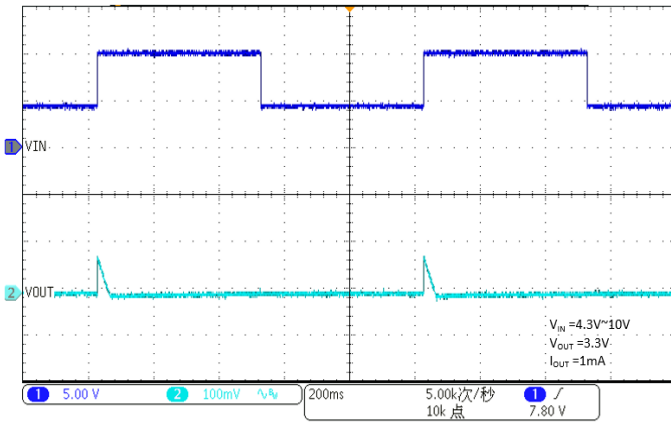

Line Transient

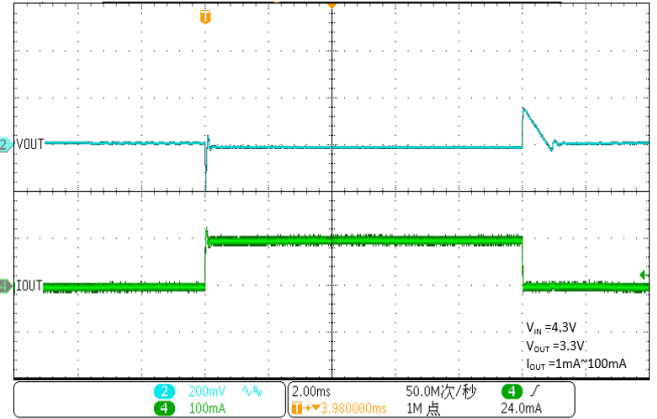

Load Transient

# WR0116

## Block Diagram

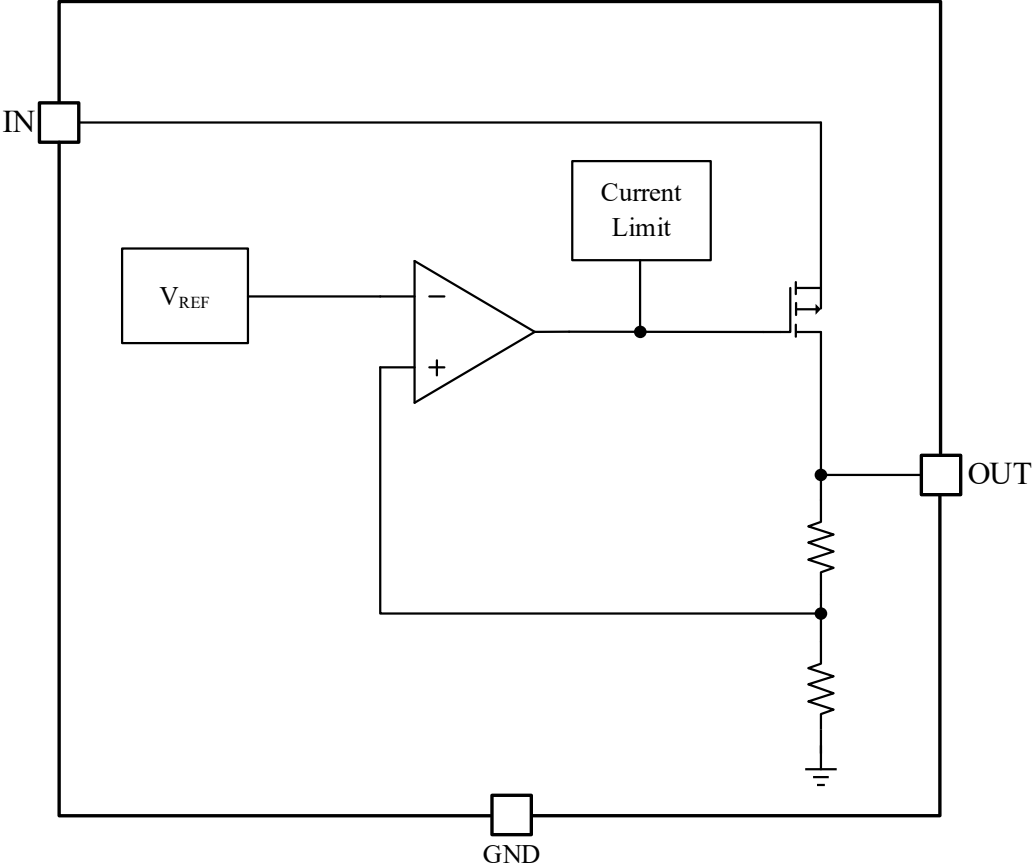

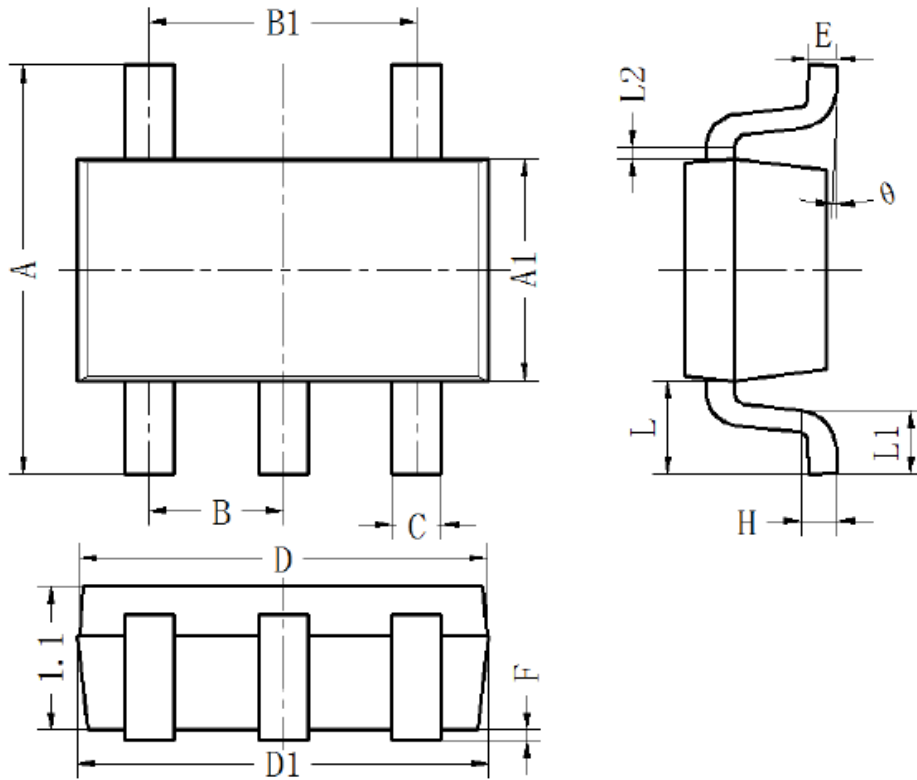

**Package Information**

**SOT23-5L**

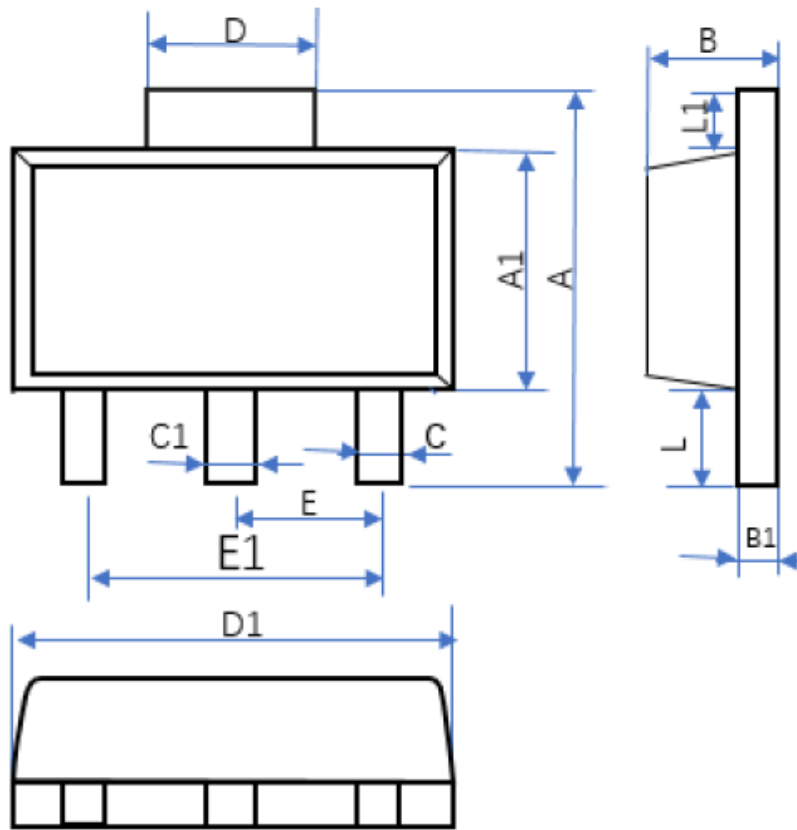
SYMBOL	DIMENSIONS IN MILLIMETERS		
	MIN	NOM	MAX
<b>A</b>	2.8	2.9	3.0
<b>A1</b>	1.5	1.6	1.7
<b>B</b>	0.90	0.95	1.0
<b>B1</b>	1.8	1.9	2.0
<b>C</b>	0.35	0.4	0.45
<b>D</b>	2.79	2.89	2.99
<b>D1</b>	2.82	2.92	3.02
<b>E</b>	0.1	0.15	0.2
<b>F</b>	0.02	0.08	0.14
<b>H</b>	0.254	0.254	0.254
<b>L</b>	0.55	0.65	0.75
<b>L1</b>	0.35	0.45	0.55
<b>L2</b>	0.08	0.08	0.08
<b><math>\theta</math></b>	2		8

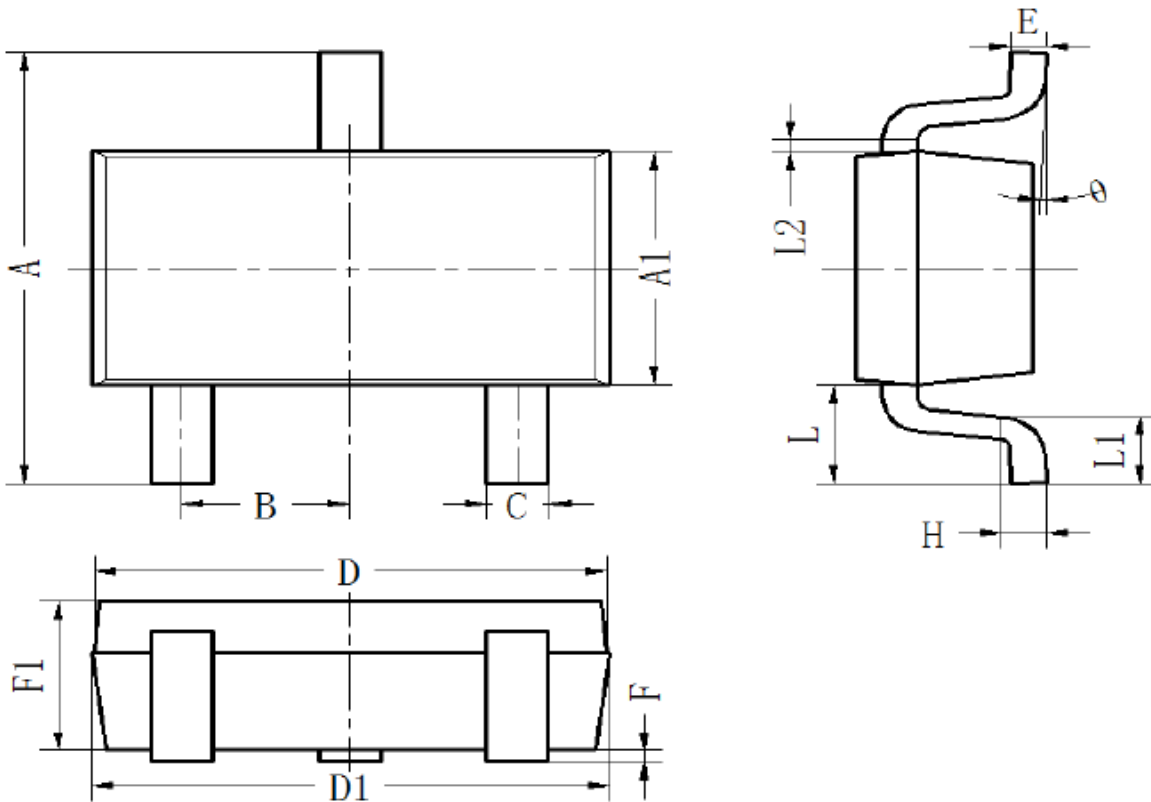

SOT89-3L

SYMBOL	DIMENSIONS IN MILLIMETERS		
	MIN	NOM	MAX
A	3.95	4.10	4.25
A1	2.45	2.50	2.55
B	1.44	1.49	1.54
B1	0.35	0.40	0.45
C	0.35	0.40	0.45
C1	0.45	0.50	0.55
D	1.65	1.70	1.75
D1	4.45	4.50	4.55
E	1.45	1.50	1.55
E1	2.95	3.00	3.05
L	0.95	1.02	1.09
L1	0.55	0.60	0.65



**SOT23-3L**

SYMBOL	DIMENSIONS IN MILLIMETERS		
	MIN	NOM	MAX
<b>A</b>	2.65	2.8	2.95
<b>A1</b>	1.5	1.6	1.7
<b>B</b>	0.90	0.95	1.00
<b>C</b>	0.3	0.4	0.5
<b>D</b>	2.82	2.92	3.02
<b>D1</b>	2.87	2.92	2.97
<b>E</b>	0.1	0.15	0.2
<b>H</b>	0.204	0.254	0.304
<b>L</b>	0.55	0.65	0.75
<b>L1</b>	0.3	0.45	0.6
<b>L2</b>	0.06	0.08	0.10
<b>F1</b>	1.05	1.1	1.15
<b>F</b>	0.02	0.08	0.15

## Ordering Information

Part Number	Output Voltage	Package	Packing Quantity	Marking*
WR0116-21A31R	2.1V	SOT23-3L	3k/Reel	WR0116 21 XXXX
WR0116-22A31R	2.2V	SOT23-3L	3k/Reel	WR0116 22 XXXX
WR0116-25A31R	2.5V	SOT23-3L	3k/Reel	WR0116 25 XXXX
WR0116-27A31R	2.7V	SOT23-3L	3k/Reel	WR0116 27 XXXX
WR0116-28A31R	2.8V	SOT23-3L	3k/Reel	WR0116 28 XXXX
WR0116-30A31R	3.0V	SOT23-3L	3K/Reel	WR0116 30 XXXX
WR0116-33A31R	3.3V	SOT23-3L	3k/Reel	WR0116 33 XXXX
WR0116-36A31R	3.6V	SOT23-3L	3k/Reel	WR0116 36 XXXX
WR0116-44A31R	4.4V	SOT23-3L	3k/Reel	WR0116 44 XXXX
WR0116-45A31R	4.5V	SOT23-3L	3k/Reel	WR0116 45 XXXX
WR0116-50A31R	5.0V	SOT23-3L	3k/Reel	WR0116 50 XXXX
WR0116-A2A31R	12V	SOT23-3L	3k/Reel	WR0116 A2 XXXX
WR0116-21A51R	2.1V	SOT23-5L	3k/Reel	WR0116 21 XXXX
WR0116-22A51R	2.2V	SOT23-5L	3k/Reel	WR0116 22 XXXX
WR0116-25A51R	2.5V	SOT23-5L	3k/Reel	WR0116 25 XXXX
WR0116-27A51R	2.7V	SOT23-5L	3k/Reel	WR0116 27 XXXX
WR0116-28A51R	2.8V	SOT23-5L	3k/Reel	WR0116 28 XXXX
WR0116-30A51R	3.0V	SOT23-5L	3k/Reel	WR0116 30 XXXX
WR0116-33A51R	3.3V	SOT23-5L	3k/Reel	WR0116 33 XXXX
WR0116-36A51R	3.6V	SOT23-5L	3k/Reel	WR0116 36 XXXX
WR0116-44A51R	4.4V	SOT23-5L	3k/Reel	WR0116 44 XXXX
WR0116-45A51R	4.5V	SOT23-5L	3k/Reel	WR0116 45 XXXX
WR0116-50A51R	5.0V	SOT23-5L	3k/Reel	WR0116 50 XXXX
WR0116-A2A51R	12V	SOT23-5L	3k/Reel	WR0116 A2 XXXX
WR0116-21A21R	2.1V	SOT89-3L	1k/Reel	WR0116 21 XXXX
WR0116-22A21R	2.2V	SOT89-3L	1k/Reel	WR0116 22 XXXX
WR0116-25A51R	2.5V	SOT89-3L	1k/Reel	WR0116 25 XXXX
WR0116-27A21R	2.7V	SOT89-3L	1k/Reel	WR0116 27 XXXX
WR0116-28A21R	2.8V	SOT89-3L	1k/Reel	WR0116 28 XXXX
WR0116-30A21R	3.0V	SOT89-3L	1k/Reel	WR0116 30 XXXX
WR0116-33A21R	3.3V	SOT89-3L	1k/Reel	WR0116 33 XXXX
WR0116-36A21R	3.6V	SOT89-3L	1k/Reel	WR0116 36 XXXX
WR0116-44A21R	4.4V	SOT89-3L	1k/Reel	WR0116 44 XXXX
WR0116-45A21R	4.5V	SOT89-3L	1k/Reel	WR0116 45 XXXX

Part Number	Output Voltage	Package	Packing Quantity	Marking*
WR0116-50A21R	5.0V	SOT89-3L	1k/Reel	WR0116 50 XXXX
WR0116-A2A21R	12V	SOT89-3L	1k/Reel	WR0116 A2 XXXX

\*XXXX is variable.

## Contact Information

No.1001, Shiwan(7) Road, Pudong District, Shanghai, P.R.China.201202

Tel: 86-21-68960674 Fax: 86-21-50757680 Email: market@way-on.com

WAYON website: <http://www.way-on.com>

For additional information, please contact your local Sales Representative.

 is registered trademark of Wayon Corporation.

*Specifications are subject to change without notice.*

*The device characteristics and parameters in this data sheet can and do vary in different applications and actual device performance may vary over time*

*Users should verify actual device performance in their specific applications.*