

## DIO3340

# USB 3.1/3.0 Super-Speed 11Gbps Switch

### Features

- Wide  $V_{DD}$  Input Voltage Range: 1.5V to 5.0V
- Up to 11 Gbps for applications including USB3.0, USB3.1, 10GE, Thunderbolt, and SAS3.0
- Bi-directional operation
- Bandwidth: 11GHz(Typical)
- -0.9dB Typical Insertion Loss at 2.5GHz
- Low Active Power of 15 $\mu$ A Typ. @ 3.6V  $V_{IN}$
- Low Shutdown Power of < 0.5 $\mu$ A Max.
- Low Crosstalk: -55dB @2.5GHz
- Low Off Isolation: -27dB @ 2.5GHz
- Operation Temperature Range: -40°C to 85 °C
- 2.5KV HBM ESD Protection
- Packaged in QFN2\*3-18 and QFN2\*2-18

### Descriptions

The DIO3340 is a two pairs 2:1 data switch for USB Super Speed Gen1 and Gen2, 5 Gbps and 10 Gbps data. The DIO3340 focus on the mobile device market, for the use in Type-C applications as a reversible cable switch. It can minimize the switch channel to channel skew and channel to channel crosstalk of the super speed signals.

The DIO3340 data switches offer superior performance, support various high speed data transmission protocols, such as USB3.0, USB3.1, 10GE, Thunderbolt, and SAS3.0.

### Applications

- Smartphones
- Tablets
- Notebooks

### Block Diagram

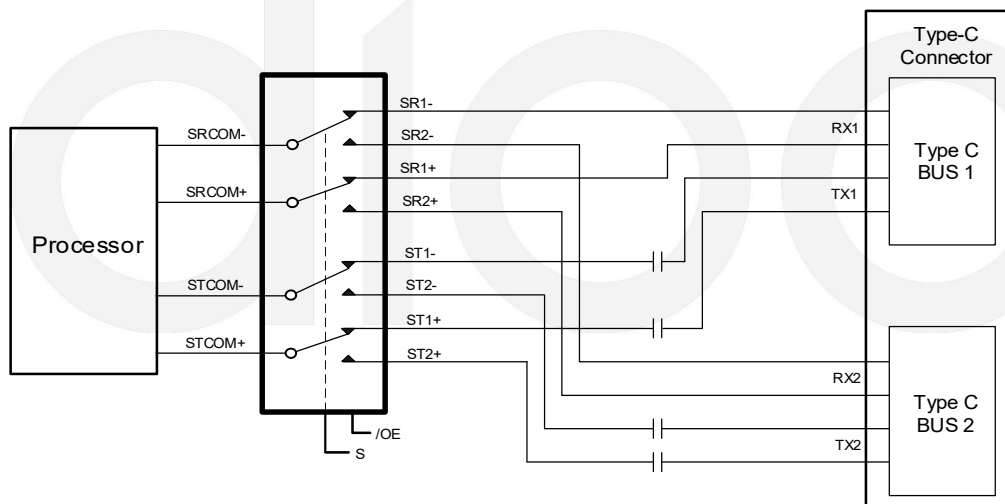

## Ordering Information

Order Part Number	Top Marking		T <sub>A</sub>	Package	
DIO3340QN18	D3DV	Green	-40 to 85°C	QFN2*3-18	Tape & Reel, 3000
DIO3340CN18	D3DV	Green	-40 to 85°C	QFN2*2-18	Tape & Reel, 3000

## Pin Assignment

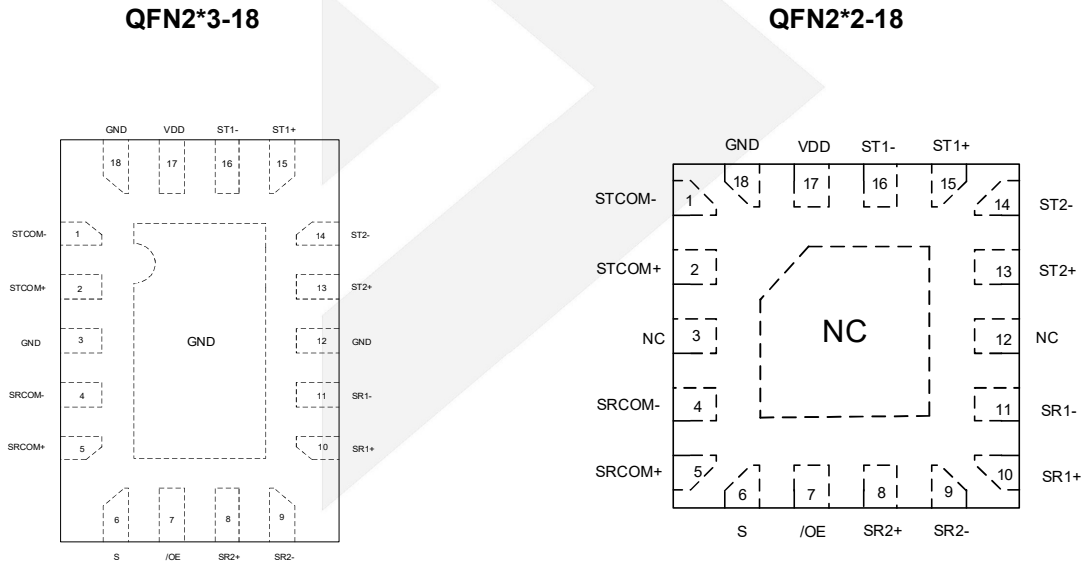

Figure 1 Top View



**Pin Descriptions**

Pin Name	Type	Description
STCOM-	SW	Super Speed TX- Common
STCOM+	SW	Super Speed TX+ Common
SRCOM-	SW	Super Speed RX- Common
SRCOM+	SW	Super Speed RX+ Common
S	Input	Switch Select (0=SW1, 1=SW2)
/OE	Input	Output Enable (0=Switches Enabled, 1=Switches Disabled)
SR2+	SW	Super Speed RX2+
SR2-	SW	Super Speed RX2-
SR1+	SW	Super Speed RX1+
SR1-	SW	Super Speed RX1-
ST2+	SW	Super Speed TX2+
ST2-	SW	Super Speed TX2-
ST1+	SW	Super Speed TX1+
ST1-	SW	Super Speed TX1-
VDD	VDD	Device Power
GND	GND	Ground
NC	NC	No connected



## Absolute Maximum Ratings

Stresses beyond those listed under "Absolute Maximum Rating" may cause permanent damage to the device. These are stress ratings only and functional operation of the device at these or any other condition beyond those indicated in the operational sections of the specifications is not implied. Exposure to absolute maximum rating conditions for extended periods may affect device reliability.

Symbol	Parameter	Rating	Unit
V <sub>DD</sub>	Supply Voltage	-0.5 to 6.0	V
V <sub>CNTRL</sub>	DC Input Voltage (S, /OE) <sup>(1)</sup>	-0.5 to V <sub>DD</sub>	V
V <sub>SW</sub>	DC Switch I/O Voltage <sup>(1,2)</sup>	-0.3 to 2.1	V
I <sub>IK</sub>	DC Input Diode Current	-50	mA
I <sub>SW</sub>	DC Switch Current	25	mA
T <sub>STG</sub>	Storage Temperature	-65 to 150	°C
ESD	Human Body Model, JEDEC: JESD22-A114	2.5	kV

**Note:**

1. The input and output negative ratings may be exceeded if the input and output diode current ratings are observed.
2. V<sub>SW</sub> refers to analog data switch paths.

## Recommend Operating Conditions

The Recommended Operating Conditions table defines the conditions for actual device operation. Recommended Operating conditions are specified to ensure optimal performance to the datasheet specifications. DIOO does not Recommend exceeding them or designing to Absolute Maximum Ratings.

Symbol	Parameter	Rating	Unit
V <sub>DD</sub>	Supply Voltage	1.5 to 5.0	V
V <sub>CNTRL</sub>	Control Input Voltage (S, /OE) <sup>(3)</sup>	0 to 5.0	V
V <sub>SW</sub>	Switch I/O Voltage (Both SSUSB Switch Paths)	0 to 2.0	V
T <sub>A</sub>	Operating Temperature Range	-40 to 85	°C

**Note:**

3. The control inputs must be held HIGH or LOW; they must not float.

## DC and Transient Characteristics

All typical values are at  $T_A=25^{\circ}\text{C}$  unless otherwise specified.

Symbol	Parameter	Conditions	$V_{DD}(\text{V})$	Min.	Typ.	Max.	Unit
$V_{IH}$	Control Input Voltage High	S, /OE	1.5	1.3			V
		S, /OE	3.6	1.4			
		S, /OE	5.0	1.5			
$V_{IL}$	Control Input Voltage Low	S, /OE	1.5			0.4	V
		S, /OE	3.6			0.4	
		S, /OE	5.0			0.4	
$I_{IN}$	Control Input Leakage	$V_{SW} = -0.6$ to $2.0\text{V}$ $V_{CNTRL} = 0$ to $V_{DD}$	5.0	-500		500	nA
$I_{OZ}$	Off-State Leakage for Open Data Paths	$V_{SW} = 0.0 \leq \text{DATA} \leq 2.0\text{V}$	5.0	-0.5		0.5	$\mu\text{A}$
$I_{CL}$	On-State Leakage for Closed Data Paths <sup>(4)</sup>	$V_{SW} = 0.0 \leq \text{DATA} \leq 2.0\text{V}$	5.0	-0.5		0.5	$\mu\text{A}$
$I_{OFF}$	Power-Off Leakage Current (All I/O Ports)	$V_{SW} = 0\text{V}$ or $2.0\text{V}$	0	-500		500	nA
$R_{ON}$	Switch On Resistance	$V_{SW} = 0\text{V}$ , $I_{ON} = -8\text{mA}$	1.5		6	8	$\Omega$
$\Delta R_{ON}$	Difference in $R_{ON}$ Between Positive-Negative	$V_{SW} = 0\text{V}$ , $I_{ON} = -8\text{mA}$	1.5		0.1		$\Omega$
$R_{ONF}$	Flatness for $R_{ON}$	$V_{SW} = 0.0 \leq \text{DATA} \leq 2.0\text{V}$ , $I_{ON} = -8\text{mA}$	1.5			0.5	$\Omega$
$I_{CC}$	Quiescent Supply Current	$V_{IOE} = 0$ , $V_{SEL} = 0$ or $V_{DD}$ , $I_{OUT} = 0$	5.0		21	30	$\mu\text{A}$
$I_{CCZ}$	Quiescent Supply Current (High Impedance)	$V_{SEL} = X$ , $V_{IOE} = V_{DD}$ , $I_{OUT} = 0$	5.0			0.5	$\mu\text{A}$
$I_{CCT}$	Increase in Quiescent Supply Current per $V_{CNTRL}$	$V_{SEL}$ or $V_{IOE} = 1.5\text{V}$	5.0		7	15	$\mu\text{A}$

**Note:**

4. For this test, the data switch is closed with the respective switch pin floating.

## AC Electrical Characteristics

All typical values are at  $V_{DD}=3.6V$ ,  $T_A=25^{\circ}C$  unless otherwise specified.

Symbol	Parameter	Conditions	$V_{DD}(V)$	Min.	Typ.	Max.	Unit
$t_{ON}$	Turn-On Time, S to Output	$R_L=50\Omega$ , $C_L=0pF$ , $V_{SW}=0V$ , $V_{SW}=0.6V$	1.5 to 5.0V		420	700	ns
$t_{OFF}$	Turn-Off Time, S to Output	$R_L=50\Omega$ , $C_L=0pF$ , $V_{SW}=0V$ , $V_{SW}=3.3V$	1.5 to 5.0V		60	300	ns
$t_{ZHM,ZL}$	Enable Time,/OE to Output	$R_L=50\Omega$ , $C_L=0pF$ , $V_{SW}=0.6V$	1.5 to 5.0V		53	150	$\mu s$
$t_{LZM,HZ}$	Disable Time,/OE to Output	$R_L=50\Omega$ , $C_L=0pF$ , $V_{SW}=0.6V$	1.5 to 5.0V		100	300	ns
$t_{PD}$	Propagation Delay <sup>(5)</sup>	$C_L=0pF$ , $R_L=50\Omega$	1.5 to 5.0V		60		ps
$t_{BBM}$	Break-Before-Make <sup>(5)</sup>	$R_L=50\Omega$ , $C_L=0pF$ , $V_{SW1}=0.6V, V_{SW2}=-0.6V$	1.5 to 5.0V	120		600	ns
$DO_{IRR}$	Differential Off Isolation <sup>(5)</sup>	$V_S=0dBm$ , $R_L=50\Omega$ , $f=2.5GHz$	3.6V		-27		dB
		$V_S=0dBm$ , $R_L=50\Omega$ , $f=5.0GHz$			-20		dB
SDDNEXT	Differential Channel Crosstalk <sup>(5)</sup>	$V_S=0dBm$ , $R=50\Omega$ , $f=2.5GHz$	3.6V		-55		dB
		$V_S=0dBm$ , $R=50\Omega$ , $f=5.0GHz$			-47		dB
DIL	Differential Insertion Loss(All Data Paths) <sup>(5)</sup>	$V_{IN}=0dBm$ , $f=2.5GHz$ , $R_L=50\Omega$ , $C_L=0pF$	3.6V		-0.9		dB
		$V_{IN}=0dBm$ , $f=5.0GHz$ , $R_L=50\Omega$ , $C_L=0pF$			-1.4		
BW	Differential -3dB Bandwidth <sup>(5)</sup>	$V_{IN}=1 V_{pk-pk}$ , $R_L=50\Omega$ , $C_L=0pF$ , (Both Data Paths)	3.6V		11		GHz
$Tsk(P)$	Skew of Opposite Transitions of the Same Output <sup>(5)</sup>	$R_{PU}=50\Omega$ to $V_{DD}$ , $C_L=0pF$	3.6V		6		ps
$C_{IN}$	Control Pin Input Capacitance <sup>(5)</sup>	$V_{DD}=0V$ , $f=1MHz$			2.7		pF
$C_{ON}$	On Capacitance <sup>(5)</sup>	$V_{DD}=3.3V$ , $f=2.5GHz$			0.45		pF
$C_{OFF}$	Off Capacitance <sup>(5)</sup>	$V_{DD}=3.3V$ , $f=2.5GHz$			0.36		pF

**Note:**

5. Guaranteed by characterization.

Typical Performance Characteristics

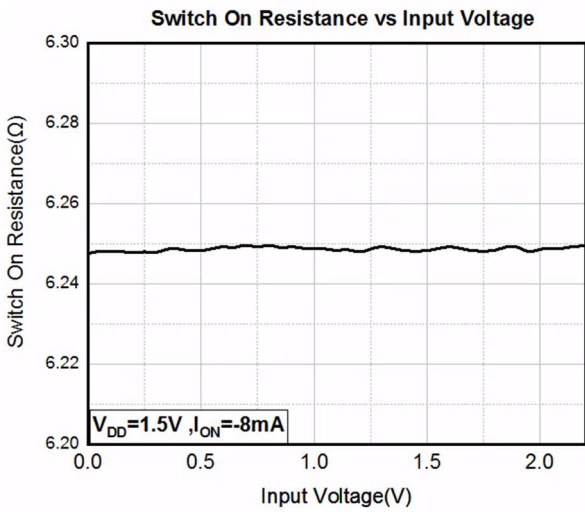

Figure 2  $R_{ON}$  VS.  $V_{IN}$

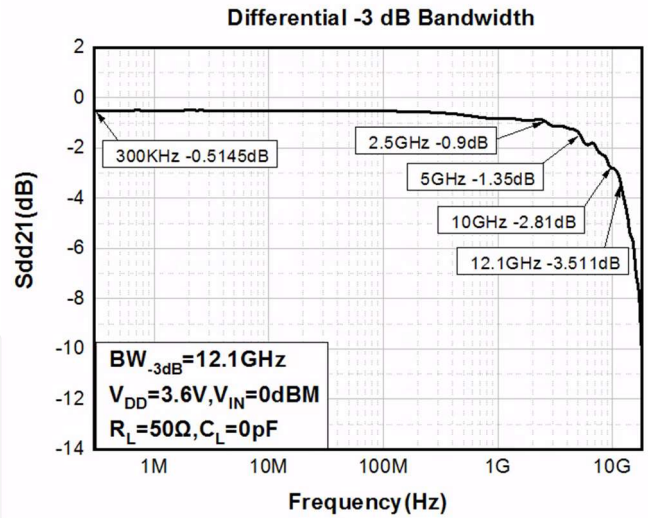

Figure 3 Different -3dB Bandwidth

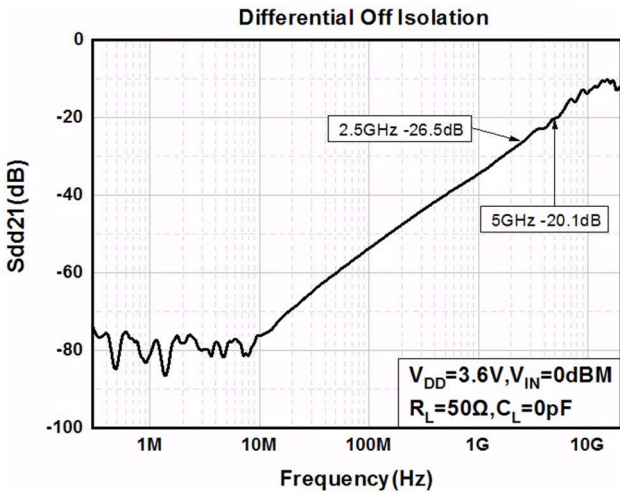

Figure 4 Different Off Isolation

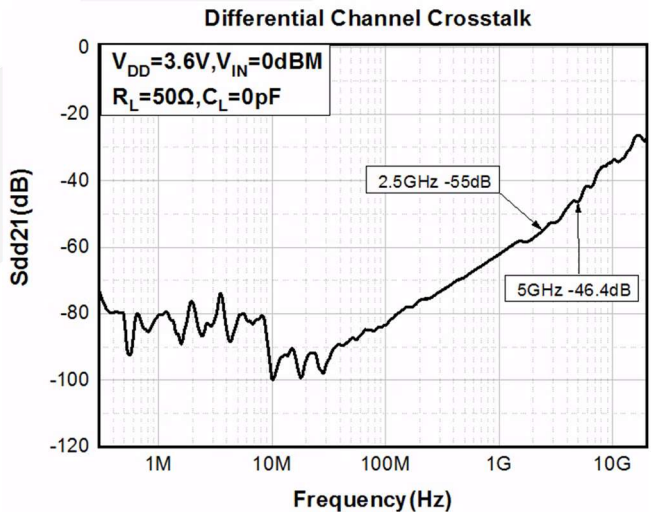

Figure 5 Differential Channel Crosstalk

Before Switch

After Switch

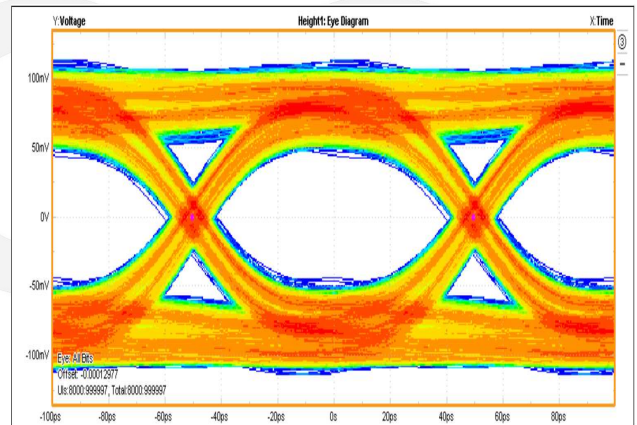
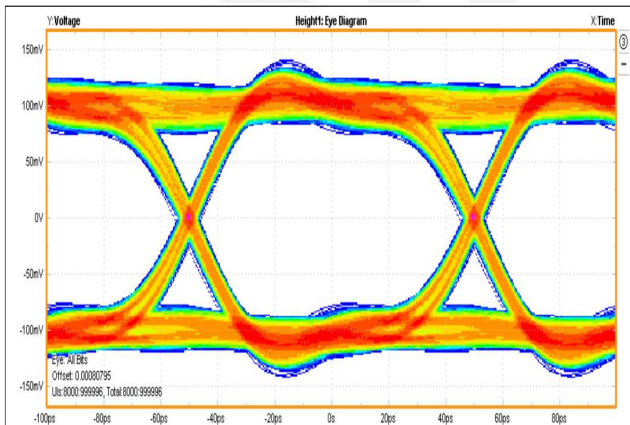

Figure 6 Eye Opening at 10Gb/s using PRBS15 pattern

## Typical Applications

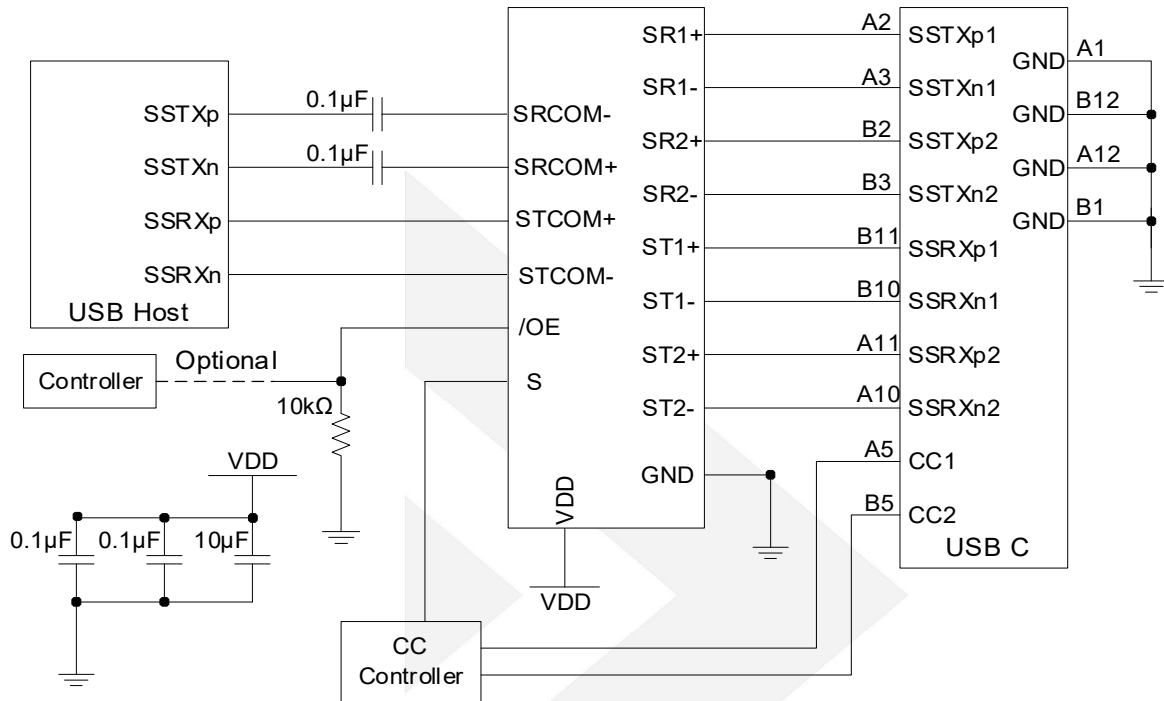

Figure 7. Down Facing Port for USB3.1 Type C Connector

## Systems Examples

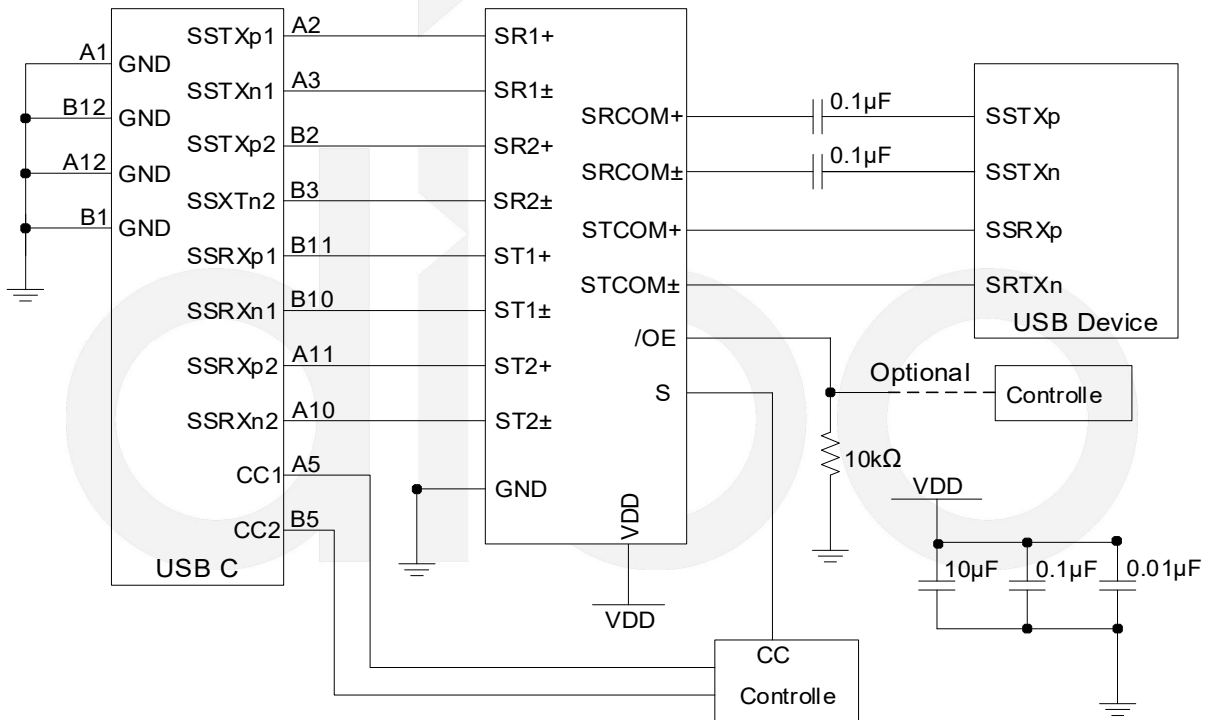

Figure 8. Up Facing Port for USB3.1 USB Type-C Connector



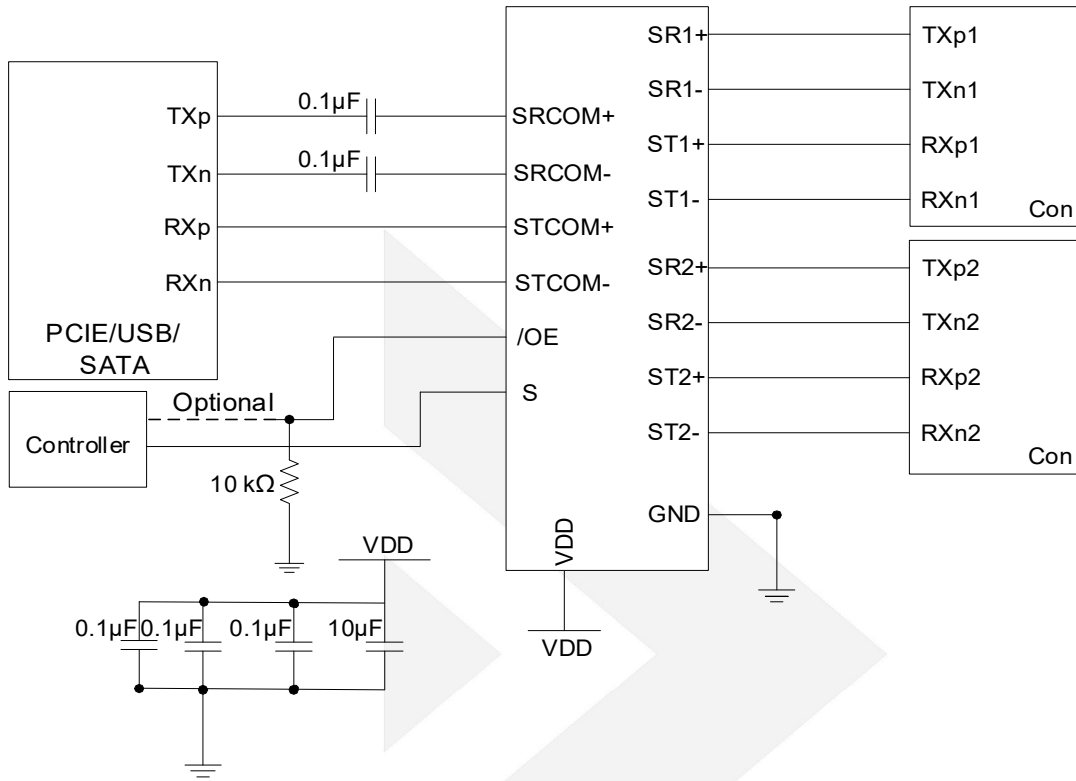

Figure 9. PCIE Motherboard

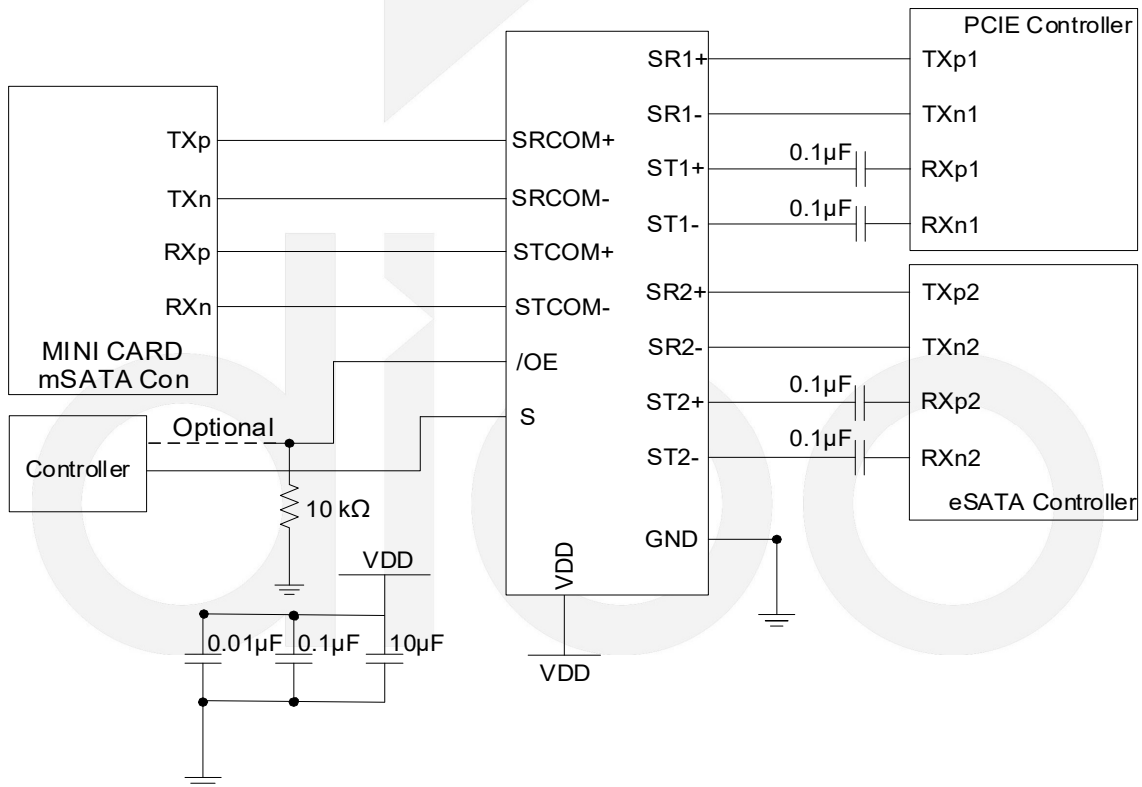

Figure10. PCIE and eSATA Combo

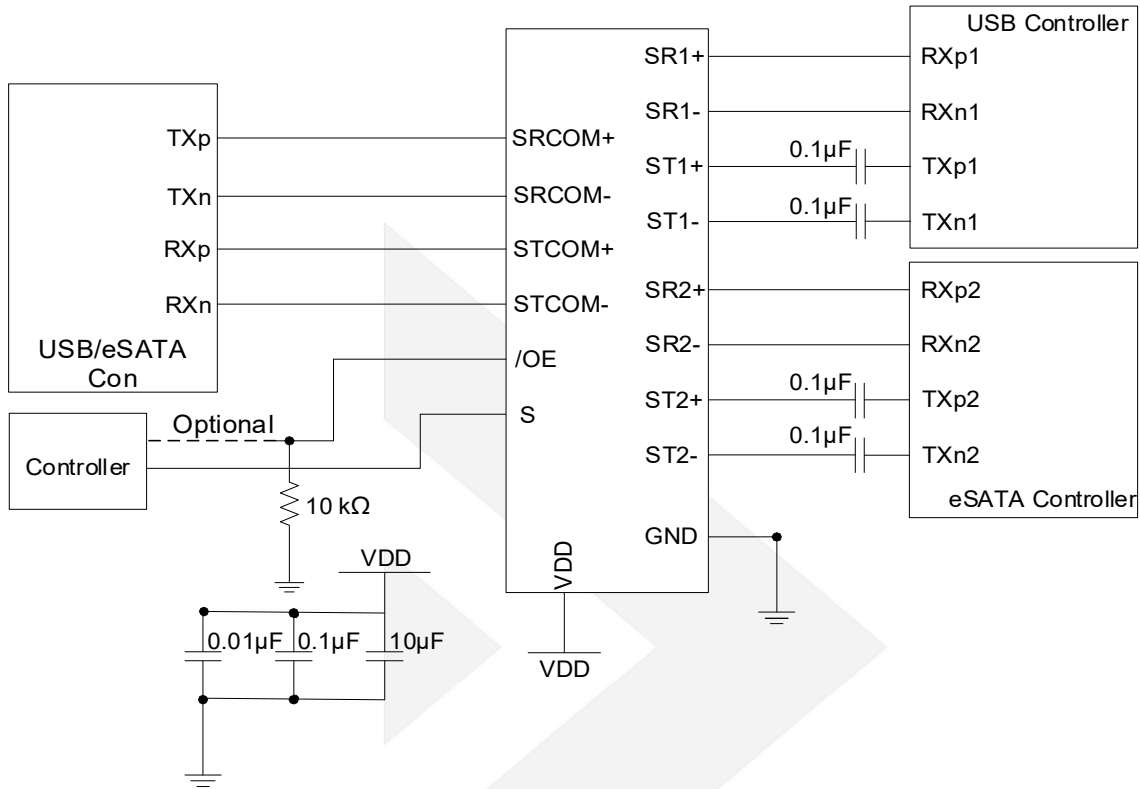

Figure 11. eSATA and USB 3.0 Combo Connector

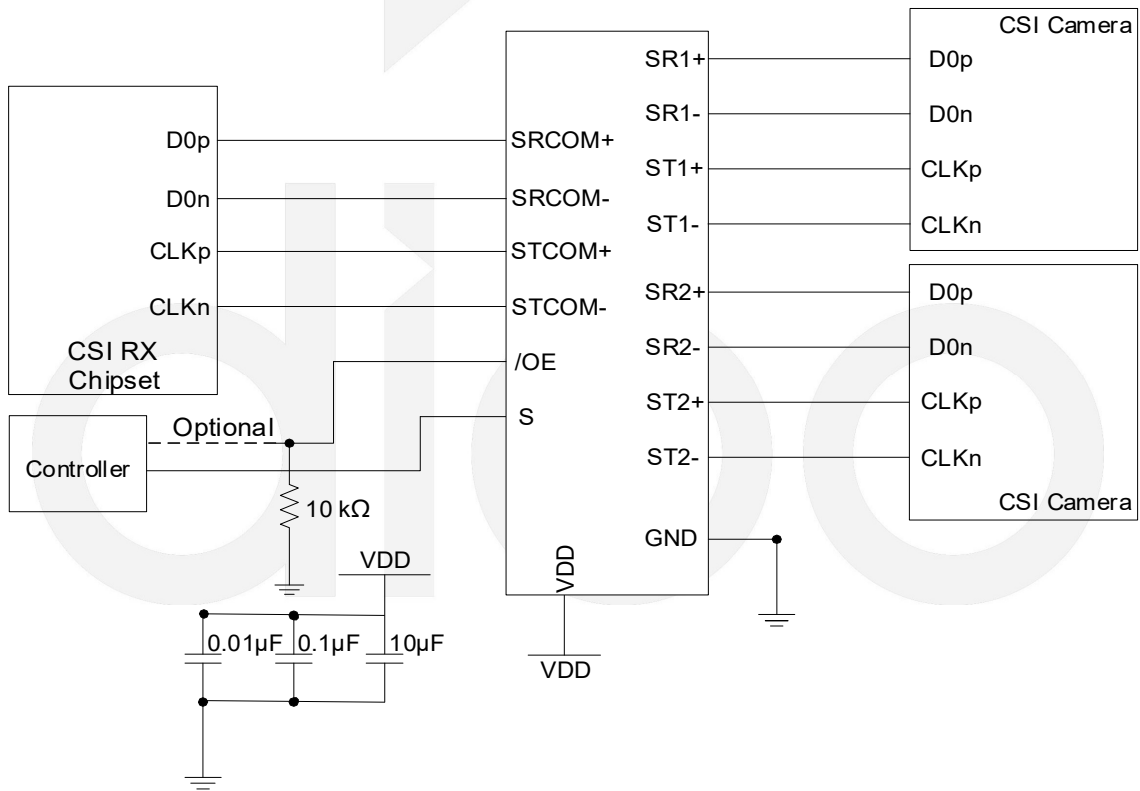
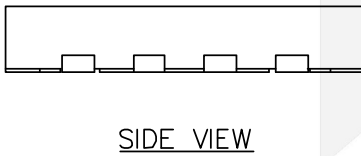
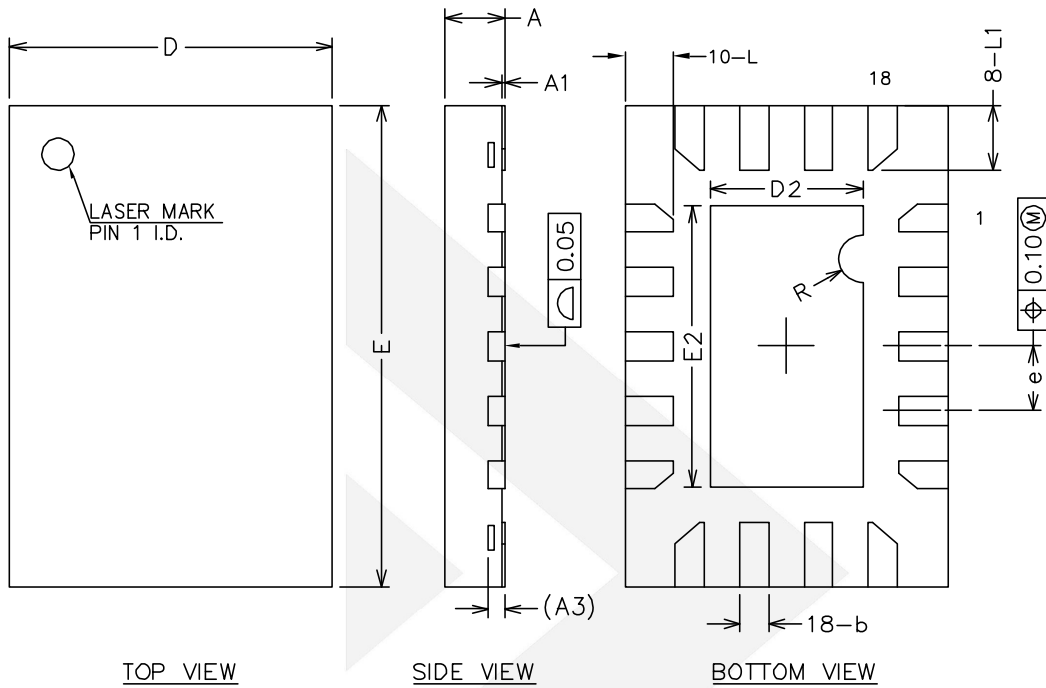

Figure 12. CSI Camera Array

### Physical Dimensions: QFN2\*3-18



COMMON DIMENSIONS(MM)			
SYMBOL	MIN	NOM	MAX
A	0.50	0.55	0.60
A1	0	0.02	0.05
A3	0.10REF		
b	0.13	0.18	0.23
D	1.90	2.00	2.10
E	2.90	3.00	3.10
D2	0.85	0.95	1.05
E2	1.65	1.75	1.85
e	0.30	0.40	0.50
L	0.25	0.30	0.60
L1	0.35	0.40	0.45
R	0.15REF		

## Physical Dimensions: QFN2\*2-18

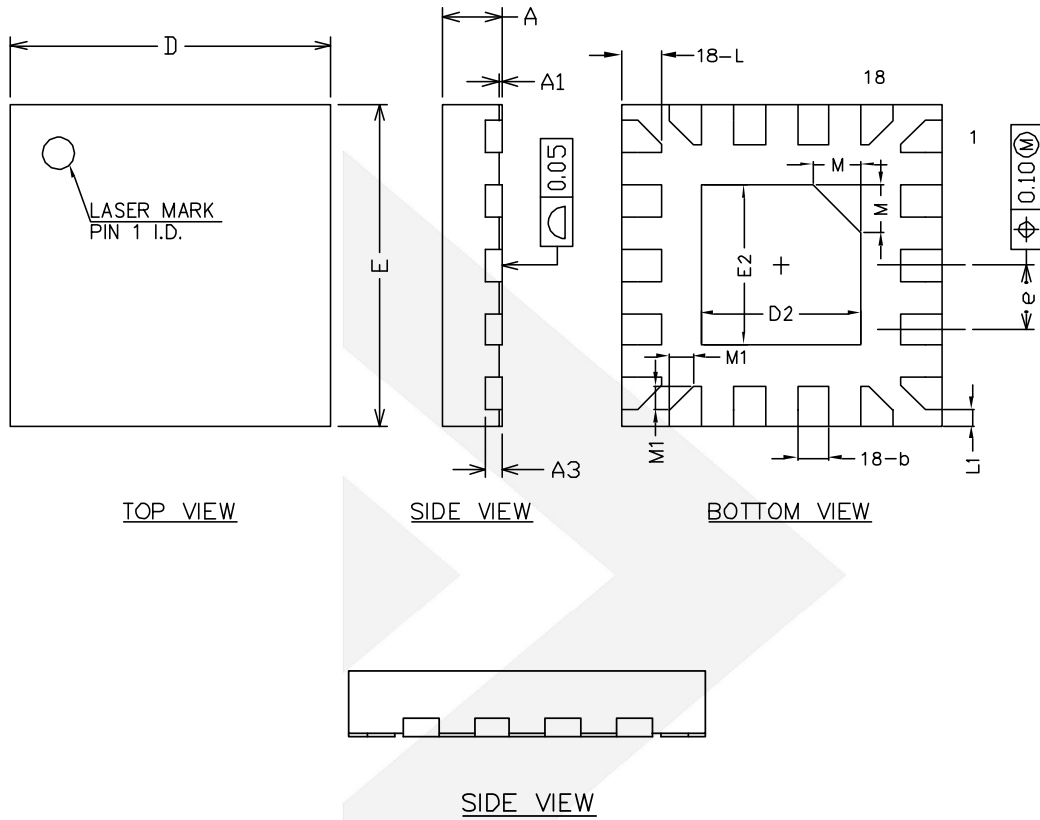

COMMON DIMENSIONS(MM)			
SYMBOL	MIN	NOM	MAX
A	0.50	0.55	0.60
A1	0	0.02	0.05
A3	0.10REF		
b	0.15	0.20	0.25
D	1.90	2.00	2.10
E	1.90	2.00	2.10
D2	0.90	1.00	1.10
E2	0.90	1.00	1.10
e	0.30	0.40	0.50
L	0.20	0.25	0.30
L1	0.05	0.10	0.15
M	0.30REF		
M1	0.15REF		

## CONTACT US

Dioo is a professional design and sales corporation for high-quality and performance analog semiconductors. The company focuses on industry markets, such as, cell phone, handheld products, laptop, and medical equipment and so on. Dioo's product families include analog signal processing and amplifying, LED drivers and charger IC. Go to <http://www.dioo.com> for a complete list of Dioo product families.

For additional product information, or full datasheet, please contact with our Sales Department or Representatives.

