

### 1. General Description

WP1130 can disconnect the systems from its output pin (OUT) in case wrong input operating conditions are detected.

The range of input voltage is up to 32V. The internal overvoltage thresholds (OVLO) is 6V, WP1130 also has internal over temperature protect (OTP) function and it can monitor chip temperature to protect the device.

The device is packaged in advanced full-Green Packaging (SOT23).

### 2. Features

- Typical  $R_{DS(ON)}$ : 450m $\Omega$  N-Channel MOSFET@5V/0.5A
- $V_{IN}$  Range: 3.5V to 32V
- Internal Overvoltage Lockout: 6V(Typ.)
- Overvoltage-Protection Response Time: 50ns
- Startup Debounce Time: 15ms (Typ.)
- Internal Thermal-Shutdown Protection
- ESD Protected: Human Body Model:  $\pm 2KV$  JESD22-A114 (All Pins)
- SOT23 Package

### 3. Applications

- Smartphones, Tablet PC
- HDD, Storage and Solid State Memory Devices
- Portable Media Devices, Laptop & MID
- SLR Digital Cameras
- GPS and Navigation Equipment
- Industrial Handheld and Enterprise Equipment

### 4. Typical Application

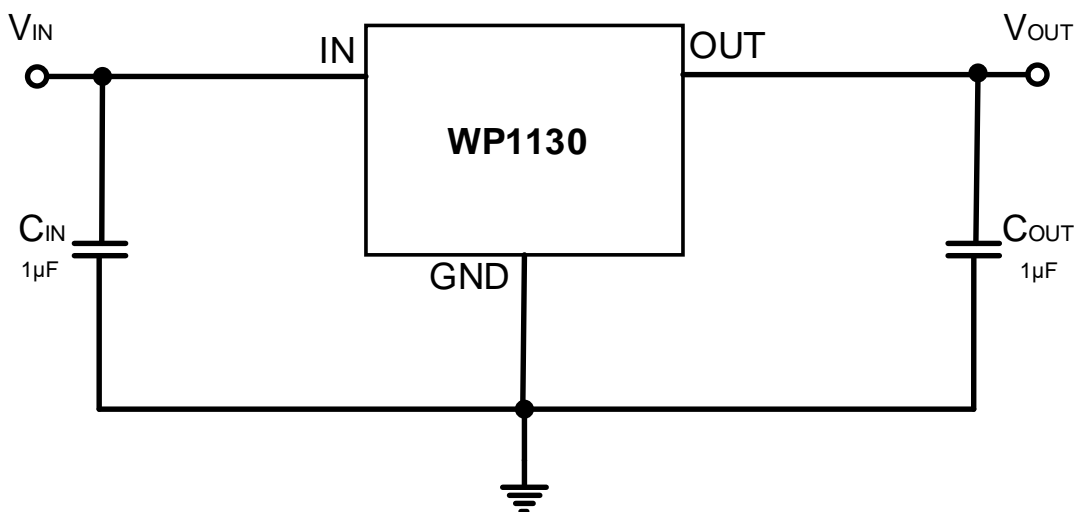

- \*NOTE:**
1. This circuit only supplies for reference.
  2. For hot swap applications, a 0.1µF capacitance ( $C_{IN}$ ) is recommended at the input.

## 5. Pin Configuration

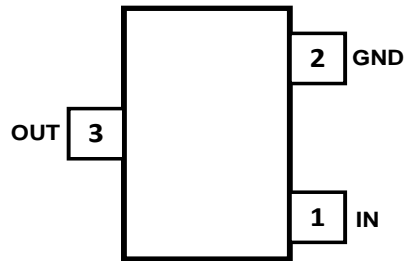

SOT23

## 6. Pin Description

PIN NAME	PIN NUMBER	I/O	PIN FUNCTION
IN	1	I	Switch input.
GND	2	—	Ground.
OUT	3	O	Switch Output.

## 7. Absolute Maximum Ratings <sup>[1]</sup>

$T_A=25^{\circ}\text{C}$ , unless otherwise noted.

SYMBOL	PARAMETER	RATING	UNIT
$V_{IN}$	IN Voltage	-0.3 to 34	V
$V_{OUT}$	OUT Voltage	-0.3 to 7	V
$I_{OUT\_MAX}$	Maximum Continuous Current	0.7(MAX)	A
$T_{J(MAX)}$	Junction Temperature	150	$^{\circ}\text{C}$
$T_{STG}$	Storage Temperature	-65 to 150	$^{\circ}\text{C}$
$T_{SDR}$	Soldering Temperature (Reflow)	260	$^{\circ}\text{C}$
$V_{ESD}$	HBM	$\pm 2000$	V

**NOTE 1:** Stresses beyond those listed under Absolute Maximum Ratings may cause permanent damage to the device. These are stress ratings only, which do not imply functional operation of the device at these or any other conditions beyond those indicated under Recommended Operating Conditions. Exposure to absolute-maximum-rated conditions for extended periods may affect device reliability.

## 8. Recommended Operating Conditions

SYMBOL	PARAMETER	MIN	MAX	UNIT
$V_{IN}$	Input Voltage	3.5	32	V
$T_A$	Operating Ambient Temperature	-40	85	$^{\circ}\text{C}$

## 9. Electrical Characteristics

( $V_{IN}=5\text{ V}$ ,  $C_{IN}=1\mu\text{F}$ ,  $C_{OUT}=1\mu\text{F}$ ,  $T_A=25^\circ\text{C}$ , unless otherwise noted)

SYMBOL	PARAMETER	TEST CONDITIONS	MIN	TYP	MAX	UNIT
<b>Basic Operation</b>						
$V_{IN}$	Input Voltage		3.5		32	V
$I_{IN}$	$V_{IN}$ Quiescent Current	$V_{IN}=5\text{V}$ , OUT Floating		75		$\mu\text{A}$
$R_{ON}$	On-Resistance of Switch IN-OUT	$V_{IN}=5\text{V}$ , $I_{OUT}=0.5\text{A}$		450		$\text{m}\Omega$
$V_{OVLO}$	OVP Trip Level	$V_{IN}$ Rising	5.5	6.0	6.5	V
$V_{OVLO-HYS}$	Hysteresis of OVP Trip Level	$V_{IN}$ Falling		0.15		V
<b>Over Temperature Protection (OTP)</b>						
$T_{SD}$	Thermal Shutdown	$V_{IN}=5\text{V}$		170		$^\circ\text{C}$
$\Delta T_{SD}$	Thermal Shutdown Hysteresis	$V_{IN}=5\text{V}$		30		$^\circ\text{C}$
<b>Dynamic Characteristics</b>						
$t_{DEB}$	Debounce Time	Time from $2.5\text{V} < V_{IN} < V_{OVLO}$ to $V_{OUT} = 10\%$ of $V_{IN}$		15		ms
$t_{ON}$	Switch Turn-on Time	$R_L=100\Omega$ , $V_{OUT}$ from $10\%V_{IN}$ to $90\%V_{IN}$		0.03		ms
$t_{OFF\_RES}^{[2]}$	Switch Turn-off Response Time	$R_L=100\Omega$ , $C_L=0\mu\text{F}$ , $V_{IN} > V_{OVLO}$ to $V_{OUT}$ Stop Rising		50		ns

**NOTE 2:** Guaranteed by design. The Switch Turn-off Response Time may vary with respect to  $V_{IN}$  slew rate.

**NOTE 3:** Limits over full temperature are guaranteed by design, but not tested in production.

### 10. Typical Performance Characteristics

( $V_{IN} = 5V$ ,  $C_1 = 1\mu F$ ,  $C_2 = 1\mu F$ ,  $T_A = 25^\circ C$ , unless otherwise noted)

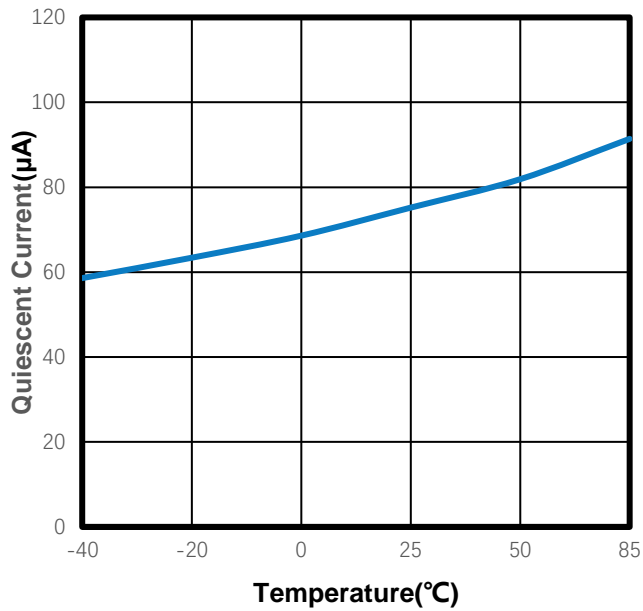

Figure 1. Quiescent Current vs. Ambient Temperature

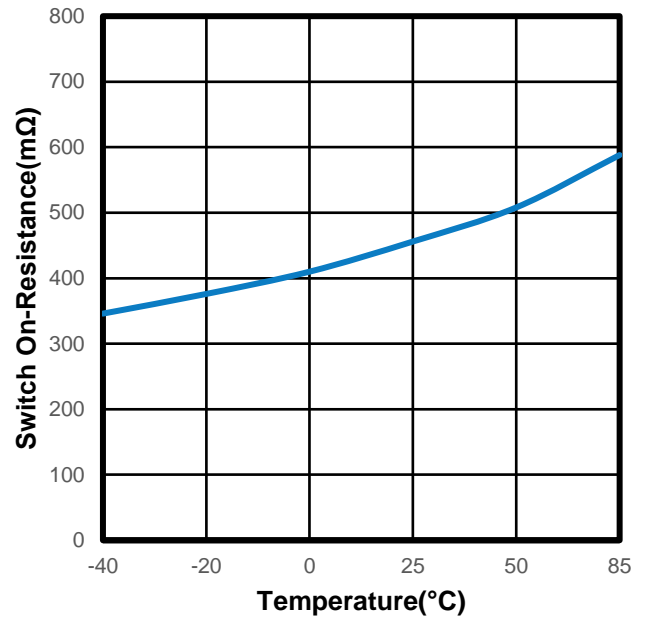

Figure 2. On-Resistance vs. Ambient Temperature

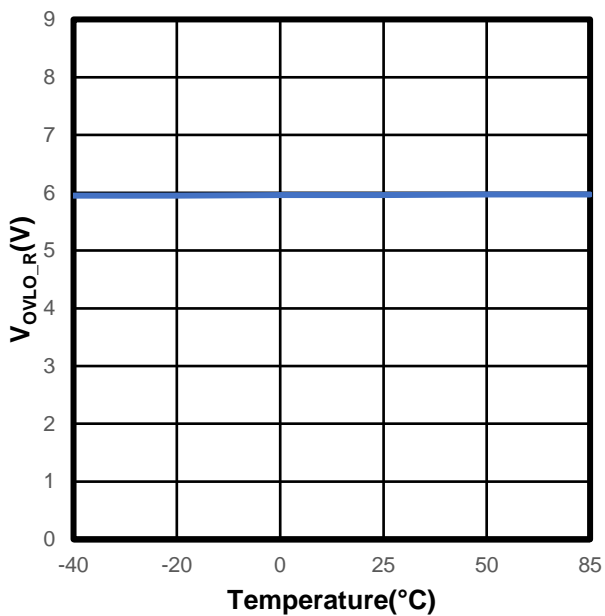

Figure 3. V\_OVLO\_R vs. Ambient Temperature

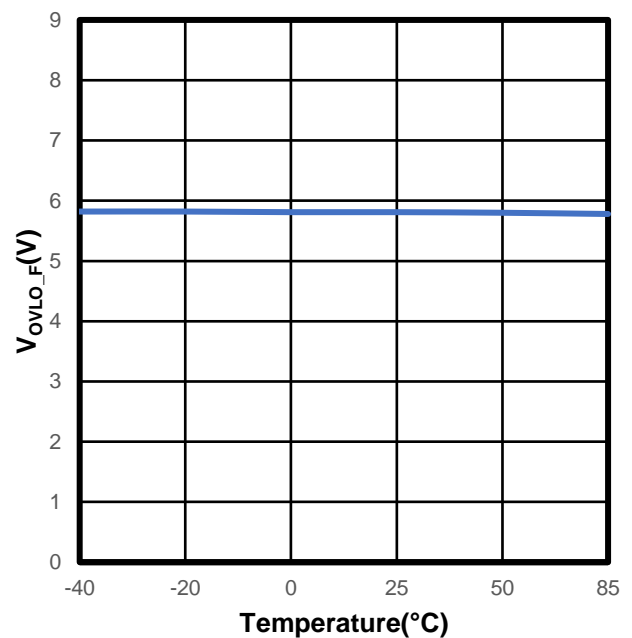
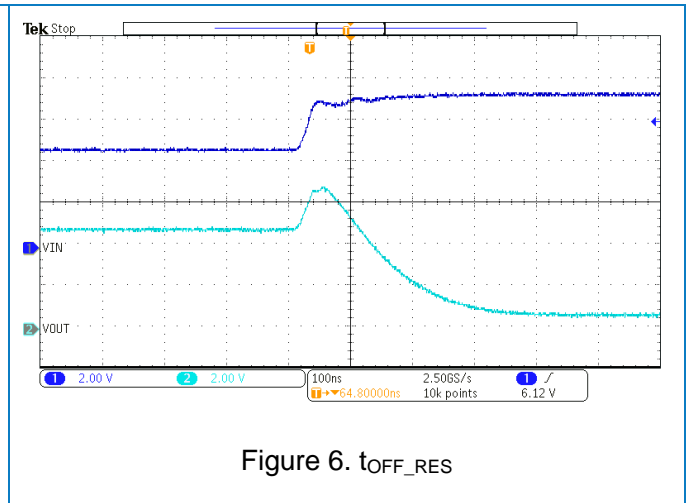
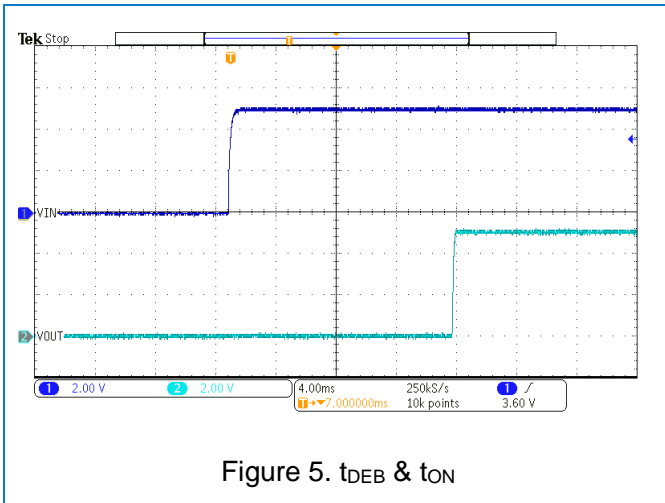

Figure 4. V\_OVLO\_F vs. Ambient Temperature



## 11. Function Description

### 11.1 Overview

The WP1130 with overvoltage protection features a low 450mΩ (Typ.)  $R_{DS(ON)}$  of internal FET and protects low-voltage systems against voltage faults up to 32V<sub>DC</sub>. If the  $V_{IN}$  exceeds 6.0V, the internal FET is quickly turned off to prevent the downstream components from damage.

The internal FET turns off when the junction temperature exceeds 170°C (Typ.). The device exits thermal shutdown after the junction is cooled down by 30°C (Typ.).

### 11.2 Block Diagram

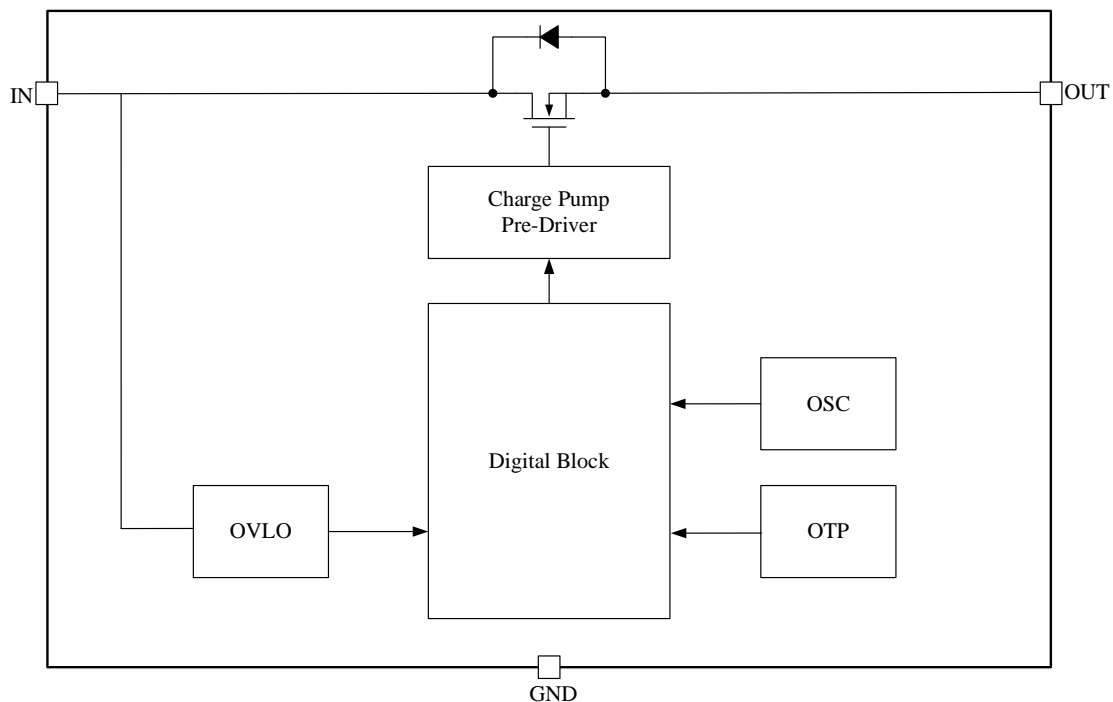

### 11.3 Feature Description

#### 11.3.1 Over Temperature Protection (OTP)

The WP1130 monitors its own internal temperature to prevent thermal failures. The device turns off the internal FET when the junction temperature reaches 170°C. The device will resume after the junction is cooled down by 30°C.

#### 11.3.3 Input Over Voltage Protection (OVP)

If the input voltage exceeds the WP1130 rising trip level, the switch will be turned off in about 50ns. The switch will remain off until  $V_{IN}$  falls below the WP1130 falling trip level.

## 12. Application and Implementation

### 12.1 Selection of Input Capacitor

To limit the voltage drops on the input supply caused by transient inrush current, a capacitor must be placed between the IN and GND pins.

### 12.2 Selection of Output Capacitor

A capacitor should be placed between the OUT and GND pins.

## 13. Evaluation Modules

Evaluation Modules (EVMs) are available to help evaluate initial circuit performance. We have evaluation modules for different packages, you can contact us to get the evaluation module or schematic.

The module names are listed in the following table.

Name	Package	Evaluation Module
WP1130	SOT23	EFUSES_EVM_V1.0 SOT23_WP1130

### Layout Guidelines

For best performance, all traces should be as short as possible, the input and output capacitors should be placed close to the device to minimize the effects that parasitic trace inductances may have on normal and short-circuit operation. Using wide traces for  $V_{IN}$ ,  $V_{OUT}$ , and GND will help minimize parasitic electrical effects and minimize the case to ambient thermal impedance.

### Layout Example





## 14. Naming Conventions

---

### WP AB CC-DDD E

- WP:** WAYON Protection IC;
- A:** Product Category –1: E-fuse;
- B:** Maximum Output Current – 1: <1A;
- CC:** Serial number;
- DDD:** Package – S30: SOT23;
- E:** R-Reel & T-tube;

**15. Package Information**

**SOT-23**

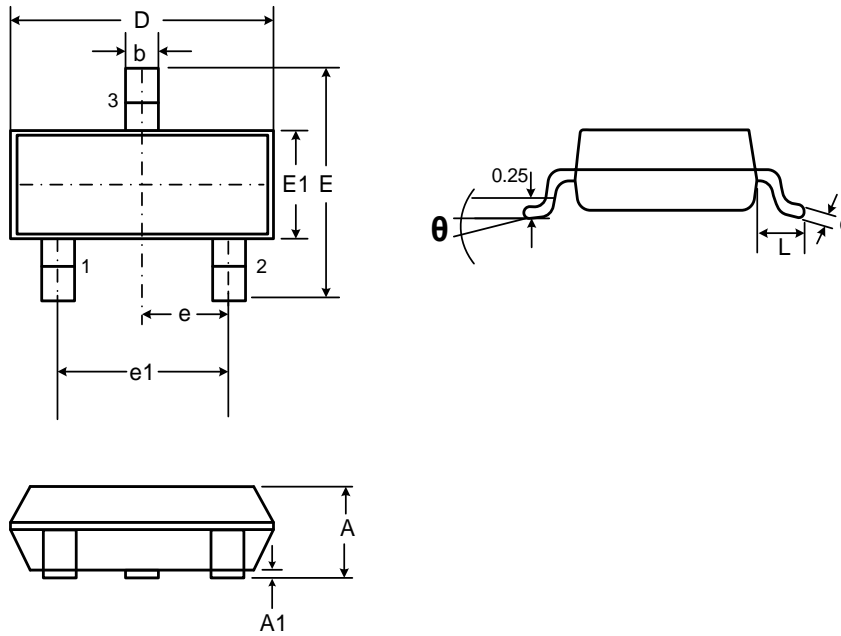

SYMBOL	DIMENSIONS IN MILLIMETERS		
	MIN	NOM	MAX
A	0.90	1.025	1.15
A1	0.00	0.05	0.10
b	0.30	0.40	0.50
c	0.07	0.11	0.15
D	2.80	2.92	3.04
E	2.25	2.445	2.64
E1	1.20	1.30	1.40
e	0.95 BSC		
e1	1.80	1.90	2.00
L	0.55REF		
$\theta$	0°	4°	8°

## 16. Ordering Information

PART NUMBER	PACKAGE	PACKING QUANTITY	MARKING*
WP1130-S30R	SOT23	3k/Reel	WP1130 XXXX

\* XXXX is variable.

### Contact Information

No.1001, Shiwan(7) Road, Pudong District, Shanghai, P.R.China.201202

Tel: 86-21-68960674 Fax: 86-21-50757680 Email: market@way-on.com

WAYON website: <http://www.way-on.com>

For additional information, please contact your local Sales Representative.

**WAYON**® is registered trademark of Wayon Corporation.

*Specifications are subject to change without notice.*

*The device characteristics and parameters in this data sheet can and do vary in different applications and actual device performance may vary over time.*

*Users should verify actual device performance in their specific applications.*

### Product Specification Statement

- The product specification aims to provide users with a reference regarding various product parameters, performance, and usage. It presents certain aspects of the product's performance in graphical form and is intended solely for users to select product and make product comparisons, enabling users to better understand and evaluate the characteristics and advantages of the product. It does not constitute any commitment, warranty, or guarantee.
- The product parameters described in the product specification are numerical values, characteristics, and functions obtained through actual testing or theoretical calculations of the product in an independent or ideal state. Due to the complexity of product applications and variations in test conditions and equipment, there may be slight fluctuations in parameter test values. WAYON shall not guarantee that the actual performance of the product when installed in the customer's system or equipment will be entirely consistent with the product specification, especially concerning dynamic parameters. It is recommended that users consult with professionals for product selection and system design. Users should also thoroughly validate and assess whether the actual parameters and performance when installed in their respective systems or equipment meet their requirements or expectations. Additionally, users should exercise caution in verifying product compatibility issues, and WAYON assumes no responsibility for the application of the product.
- WAYON strives to provide accurate and up-to-date information to the best of our ability. However, due to technical, human, or other reasons, WAYON cannot guarantee that the information provided in the product specification is entirely accurate and error-free. WAYON shall not be held responsible for any losses or damages resulting from the use or reliance on any information in these product specifications. WAYON reserves the right to revise or update the product specification and the products at any time without prior notice, and the user's continued use of the product specification is considered an acceptance of these revisions and updates. Prior to purchasing and using the product, users should verify the above information with WAYON to ensure that the product specification is the most current, effective, and complete. If users are particularly concerned about product parameters, please consult WAYON in detail or request relevant product test reports. Any data not explicitly mentioned in the product specification shall be subject to separate agreement.
- Users are advised to pay attention to the parameter limit values specified in the product specification and maintain a certain margin in design or application to ensure that the product does not exceed the parameter limit values defined in the product specification. This precaution should be taken to avoid exceeding one or more of the limit values, which may result in permanent irreversible damage to the product, ultimately affecting the quality and reliability of the system or equipment.
- The design of the product is intended to meet civilian needs and is not guaranteed for use in harsh environments or precision equipment. It is not recommended for use in systems or equipment such as medical devices, aircraft, nuclear power, and similar systems, where failures in these systems or equipment could reasonably be expected to result in personal injury. WAYON shall assume no responsibility for any consequences resulting from such usage.
- Users should also comply with relevant laws, regulations, policies, and standards when using the product specification. Users are responsible for the risks and liabilities arising from the use of the product specification and must ensure that it is not used for illegal purposes. Additionally, users should respect the intellectual property rights related to the product specification and refrain from infringing upon any third-party legal rights. WAYON shall assume no responsibility for any disputes or controversies arising from the above-mentioned issues in any form.